



DOC-0017-10-EN-B
04.04.2023

AC20 Series

PROFINET IO– Communication Option

Technical Manual



ENGINEERING **YOUR** SUCCESS.

1 Safety

IMPORTANT: Please read this information BEFORE installing the equipment.

1.1 Intended Users

This manual is to be made available to all persons who are required to install, configure or service equipment described herein, or any other associated operation.

The information given is intended to highlight safety issues, and to enable the user to obtain maximum benefit from the equipment.

Complete the following table for future reference detailing how the unit is to be installed and used.

INSTALLATION DETAILS	
Model Number (see product label)	
Where installed (for your own information)	

1.2 Application Area





The equipment described is intended for industrial motor speed control utilizing AC induction motors or AC permanent magnet synchronous machines.

1.3 Personnel

Installation, operation, and maintenance of the equipment should be carried out by competent personnel. A competent person is someone that is technically qualified and familiar with all safety information and established safety practices; with the installation process, operation, and maintenance of this equipment, and with all the hazards involved.

1.4 Product Warnings

Special attention must be paid to the information presented in warning, caution, and information notices when they appear in this manual. Definitions of caution, warning and information notices are shown below:

 DANGER Risk of electric shock	 WARNING Hot surfaces	 Caution Refer to documentation	 Earth/Ground Protective Conductor Terminal
---	--	--	--

Application Risk

The specifications, processes and circuitry described herein are for guidance only and may need to be adapted to the user's specific application. We cannot guarantee the suitability of the equipment described in this Manual for individual applications.

Risk Assessment

Under fault conditions, power loss or unintended operating conditions, the drive may not operate as intended. In particular:



- Stored energy might not discharge to safe levels as quickly as suggested and can still be present even though the drive appears to be switched off.
- The motor's direction of rotation might not be controlled
- The motor speed might not be controlled
- The motor might be energised

A drive is a component within a drive system that may influence its operation or effects under a fault condition. Consideration must be given to:

- Stored energy
- Supply disconnects
- Sequencing logic
- Unintended operation

1.5 Safety Information

Risk of Electric Shock

	DANGER!	
	Ignoring the following may result in injury:	
	<ul style="list-style-type: none"> - This equipment can endanger life by exposure to rotating machinery and high voltages. - The equipment must be permanently earthed due to the high earth leakage current, and the inverter motor must be connected to an appropriate safety earth. - Ensure all incoming supplies are isolated before working on the equipment. Be aware that there may be more than one supply connection to the inverter. - There may still be dangerous voltages present at power terminals (motor output, supply input phases, DC bus and the brake, where fitted) when the motor is at standstill or is stopped. - For measurements use only a meter to IEC 61010 (CAT III or higher). Always begin using the highest range. CAT I and CAT II meters must not be used on this product. - Allow at least 5 minutes for the inverter's capacitors to discharge to safe voltage levels (<50V). Use the specified meter capable of measuring up to 1000V dc & ac rms to confirm that less than 50V is present between all power terminals and between power terminals and earth. - Unless otherwise stated, this product must NOT be dismantled. In the event of a fault the inverter must be returned. Refer to "Routine Maintenance and Repair". 	

Safety & EMC Requirements

Where there is a conflict between safety and EMC requirements, personnel safety shall always take precedence.



WARNING!

Ignoring the following may result in injury or damage to equipment:



- Never perform high voltage resistance checks on the wiring without first disconnecting the inverter from the circuit being tested.
- Whilst ensuring ventilation is sufficient, provide guarding and /or additional safety systems to prevent injury or damage to equipment.
- When replacing an inverter in an application and before returning to use, it is essential that all user defined parameters for the product's operation are correctly installed.
- When replacing an inverter in an application and before returning to use, it is essential that all user defined parameters for the product's operation are correctly installed.
- All control and signal terminals are SELV, i.e. protected by double insulation. Ensure all external wiring is rated for the highest system voltage.
- Thermal sensors contained within the motor must have at least basic insulation.
- All exposed metalwork in the Inverter is protected by basic insulation and bonded to a safety earth.
- RCDs are not recommended for use with this product but, where their use is mandatory, only Type B RCDs should be used.



WARNING!

Ignoring the following may result in injury or damage to equipment:



- In a domestic environment this product may cause radio interference in which case supplementary mitigation measures may be required.
- This equipment contains electrostatic discharge (ESD) sensitive parts. Observe static control precautions when handling, installing and servicing this product.
- This is a product of the restricted sales distribution class according to IEC 61800-3. It is designated as "professional equipment" as defined in EN61000-3-2 for. Permission of the supply authority shall be obtained before connection to the public low voltage supply.

2 Manufacturing Location

Germany

Parker Hannifin Manufacturing Germany GmbH & Co. KG

Electric Motion & Pneumatic Division (EMPD)

Robert-Bosch-Strasse 22

77656 Offenburg (Germany)

Tel.: + 49 (0781) 509-0

Website: www.parker.com/eme

Certified according to ISO 9001:2015

Parker Hannifin Manufacturing Germany GmbH & Co. KG - Sitz: Bielefeld - Amtsgericht: Bielefeld HRA 15699
persönlich haftende Gesellschafterin: Parker Hannifin GmbH - Sitz: Bielefeld - Amtsgericht Bielefeld HRB 35489
Geschäftsführung der Parker Hannifin GmbH: Ulrich Jochem, Achim Kohler, Andreas Paulsen, Kirsten Stenvers
Vorsitzender des Aufsichtsrates: Dr.-Ing. Gerd Scheffel

3 Waste Electrical and Electronic Equipment (WEEE)



Waste Electrical and Electronic Equipment - must not be disposed of with domestic waste. It must be separately collected according to local legislation and applicable laws.

Parker Hannifin Company, together with local distributors and in accordance with EU directive 2002/96/EC, undertakes to withdraw and dispose of its products, fully respecting environmental considerations. For more information about how to recycle your Parker supplied waste equipment, please contact your local Parker Service Centre.

Packaging

During transport our products are protected by suitable packaging. This should be taken for central disposal as secondary raw material.

4 Table of Contents

1	Safety	2
1.1	Intended Users.....	2
1.2	Application Area.....	2
1.3	Personnel.....	2
1.4	Product Warnings.....	2
1.5	Safety Information.....	3
2	Manufacturing Location	5
3	Waste Electrical and Electronic Equipment (WEEE)	6
4	Table of Contents	7
5	Introduction	8
5.1	Product Features.....	8
6	Installation	9
6.1	Order Codes.....	9
6.2	Fitting the Option.....	10
7	Network	13
7.1	Network Connector and Cable Specification.....	13
7.2	LED Indications.....	13
8	Configuration	15
8.1	Communication parameters.....	15
8.2	Process Data.....	18
8.3	Acyclic Data Exchange.....	20
8.4	PROFINET GSDML File.....	20
9	Example Configuration and Programming	21
9.1	AC20 Motor Control Application.....	21
9.2	List of process data.....	22
9.3	Programming with Siemens PLC.....	22
10	Option Module Webserver	34
11	FTP Server	37
12	Lost Communication Trip	38
13	Diagnostic Event	39
APPENDIX A: Data types		40
APPENDIX B: Parameters		41
APPENDIX C: Setting IP-Address via Anybus IPCONFIG		44
APPENDIX D: DSE Lite Quick Start Guide		45

5 Introduction

5.1 Product Features

- Slave PROFINET Protocol
- Up to 64 modules, 8 submodules each (up to 128 submodules in total)
- Up to 1440 bytes I/O data in each direction status bytes included.
- Supports 250 μ s cycle time.
- 2 x RJ-45 PROFINET ports available simultaneously
- 100 Mbit/s, full duplex
- Galvanically isolated 2-port Ethernet interface
- IIoT (Industrial Internet of Things) ready: Includes Email Client, Web server with customizable content, SSI functionality and FTP server
- GSDML file provided
- LEDs to indicate network status (NS), Module status (MS) and Link activity (L/A)



6 Installation

DANGER!

RISK OF ELECTRIC SHOCK



Terminal covers, main covers, and cover fixings must remain in place while the drive is energized.

These should only be removed once the supply to the unit and/or system has been disconnected, and the residual energy in the DC link capacitors has been discharged.



CAUTION!

ESD SENSITIVE EQUIPMENT



Take ESD precautions when handling the Communication Interface Option Cards to avoid any risk of damaging the equipment.



- All activities covered in this chapter should be carried out when there is no power to the inverter.
- If the drive has been powered up, ensure enough time has elapsed that the inverter has discharged its residual energy.
- Always check that the voltages on the user terminals are at a safe level (<50V) before carrying out any of these activities.

6.1 Order Codes

Order Code	Description
2003-CB-00	CANopen communication interface option card
2003-EC-00	EtherCAT communication interface option card
2003-IP-00	Ethernet IP communication interface option card
2003-PB-00	Profibus DP-V1 communication interface option card
2003-PN-00	PROFINET IO communication interface option card
2003-RS-00	RS485 Modbus RTU communication interface option card

6.2 Fitting the Option

Frames 2 – 5

The Communication Interface Option Cards are intended to be customer installed. The control module housing cover will need to be removed prior to option card installation.

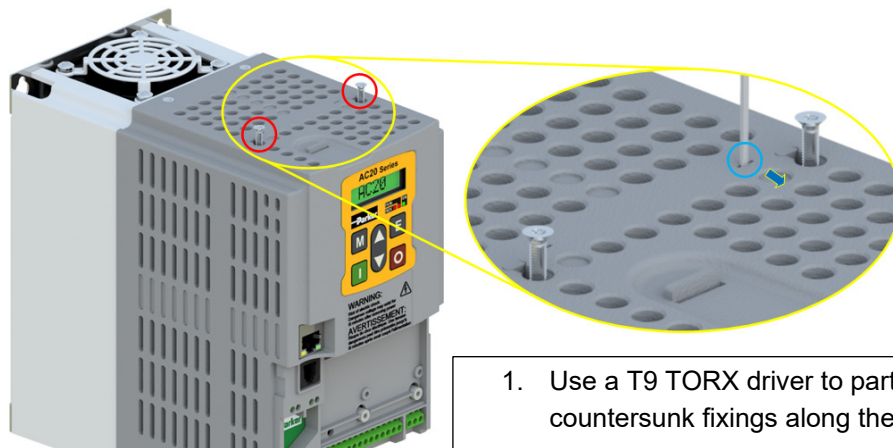

1. Use a T9 TORX driver to partially unscrew the two 3x12 countersunk fixings along the top of the product.
2. Insert a flat head screwdriver into the moulding features and lever the control module housing away from the power

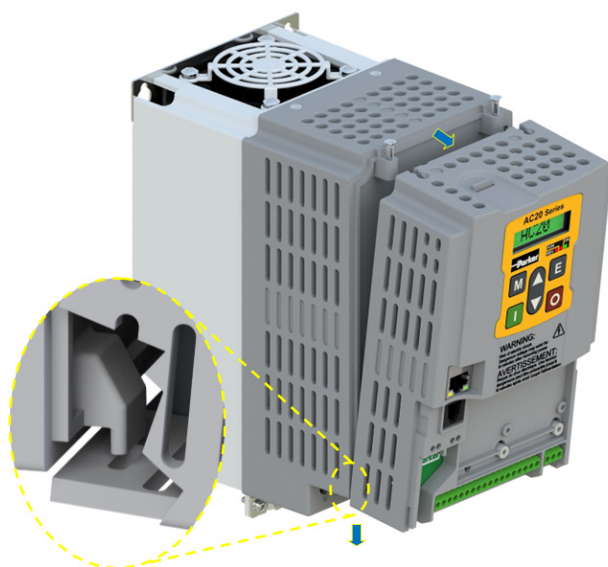

3. Unhook the bottom of the control module housing from the power stack.
4. Gently turn the control module upside down so it rests to the right of the power stack, with the interface cables still connected.

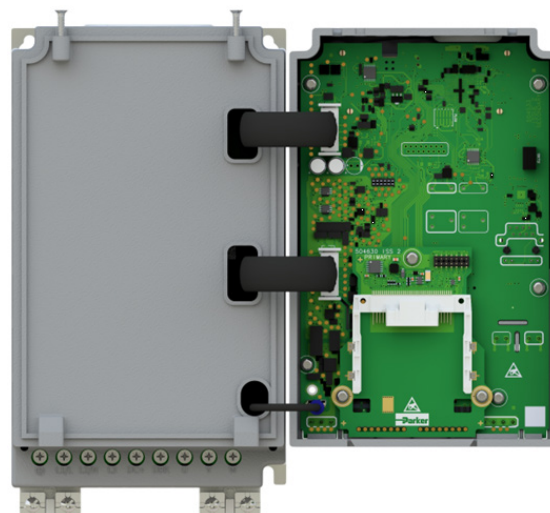

5. Remove and discard the Comms Option break-out feature in the control module housing by cutting the 7x bridges using suitable small side cutters.

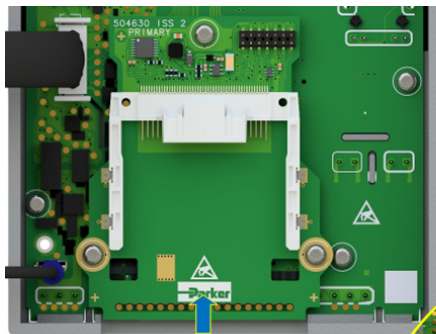
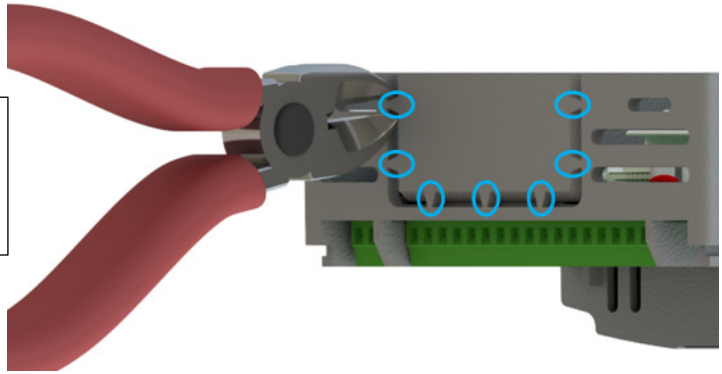

6. Remove the Comms Interface Option card from its packaging.

7. Slide the Comms Card along the PCB using the connector features for alignment.

Note: The front facia of the Option should be loose at this point.

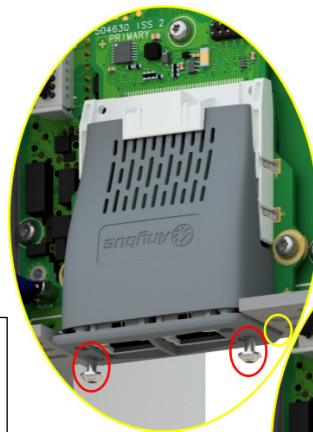

9. Now fully tighten the two T8 screws on the front facia of the Communication Interface Option Card.
10. Check that the Option Card is secure and that it cannot slide out.
11. Reassemble the product by performing the reverse process of steps 1 – 4.



In the event that the Communication Interface Option Card needs to be removed, follow the installation process, but perform steps 7 and 8 in reverse.

Frame 6 – 10

On Frames 6 – 10, the lower terminal cover will need to be removed prior to option card installation.

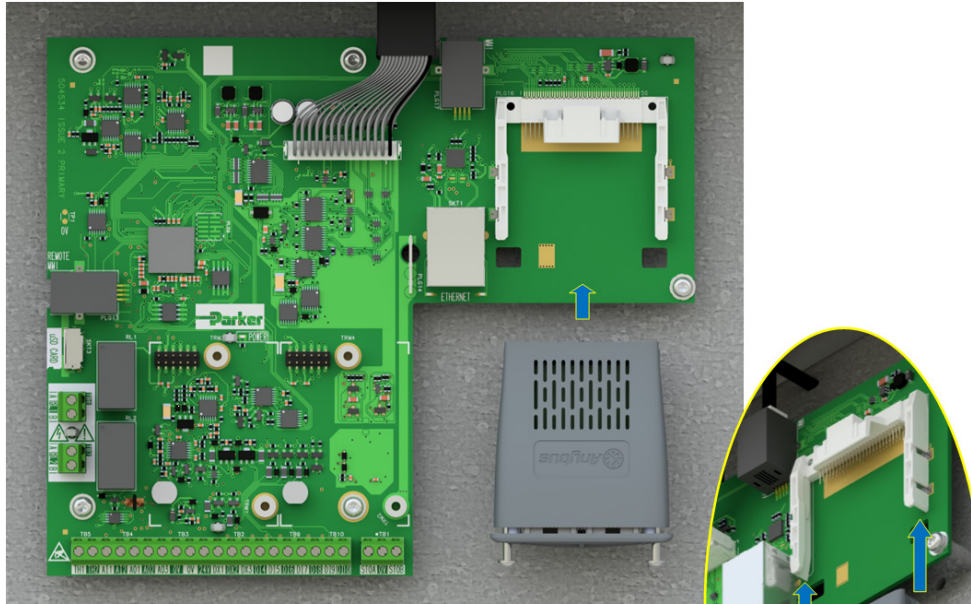

1. Remove the Comms Interface Option card from its packaging.
2. Slide the Comms Card along the PCB using the connector features for alignment.

Note: The front fascia of the Option should be loose at this point.



3. When the Comms Interface Option Card is fully engaged in the connector and its housing has hooked onto the edge of the PCB, fully tighten the two T8 screws on the front fascia.
4. Check that the Option Card is secure and that it cannot slide out.

In the event that the Communication Interface Option Card needs to be removed, perform steps 2 & 3 in reverse.

7 Network

7.1 Network Connector and Cable Specification

Two RJ45 Ethernet sockets are provided. Either or both sockets may be used. Having 2 ports reduces the need for additional Ethernet switches.



Pin	Signal
4,5,7,8	Connected to chassis ground over serial RC circuit
6	RD-
3	RD+
2	TD-
1	TD+
Housing	Cable Shield

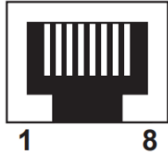

Only use cables terminated with RJ45 plugs.

7.2 LED Indications

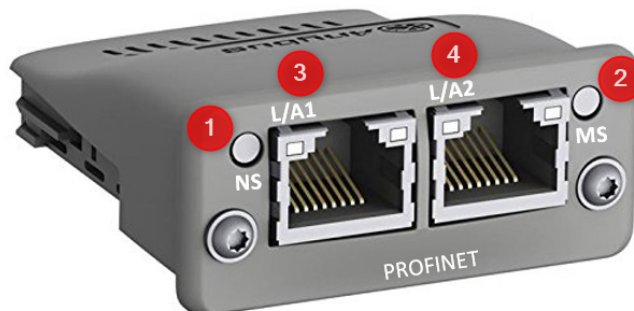

LED	Description
1	Network Status
2	Module Status
3	Link/Activity (Port 1)
4	Link/Activity (Port 2)

Network Status (NS) LED

LED Status	Description	Comments
OFF	Offline	<ul style="list-style-type: none"> No Power No Connection with IO Controller
GREEN (Solid)	Online (RUN)	<ul style="list-style-type: none"> Connection with IO Controller Established IO Controller in RUN state
GREEN, 1 Flash	Online (STOP)	<ul style="list-style-type: none"> Connection with IO Controller Established IO Controller in STOP state or IO Bad Data IRT Synchronization Not Finished
GREEN, Blinking	Blink	<ul style="list-style-type: none"> Used by Engineering Tools to Identify the Ethernet Node on the Network
RED (Solid)	Fatal Event	<ul style="list-style-type: none"> Major Internal Error (this indication is combined with a RED Module Status LED)
RED, 1 Flash	Station Name Error	<ul style="list-style-type: none"> Station Name Not Set
RED, 2 Flashes	IP-Address Error	<ul style="list-style-type: none"> IP-Address Not Set
RED, 3 Flashes	Configuration Error	<ul style="list-style-type: none"> Expected Identification Differs from Real Identification

Module Status (MS) LED

LED Status	Description	Comments
Off	Not Initialized	<ul style="list-style-type: none"> No power or Module in SETUP or NW_INIT state.
Green	Normal Operation	<ul style="list-style-type: none"> Module has shifted from the NW_INIT state
Green, 1 flash	Diagnostic Event(s)	<ul style="list-style-type: none"> Diagnostic event(s) present
Red	Exception error	<ul style="list-style-type: none"> Device in state Exception.
Alternating RED/GREEN	Fatal event	<ul style="list-style-type: none"> Major internal error (this indication is combined with a red network status LED)

Link/Activity (L/A) LED

LED Status	Description	Comments
Off	No Link	<ul style="list-style-type: none"> No Link, No Communication present.
Green (Solid)	Link	<ul style="list-style-type: none"> Ethernet Link Established, No Communication present
Green, Flickering	Network Activity	<ul style="list-style-type: none"> Ethernet Link Established, Communication Present

8 Configuration

The option comms configuration is accessible through the keypad under the menu **Option Comms**, through DSE Lite function block **Option Comms Config** or through the webserver following the path **Home > Engineer > Communications > Option Comms**.

The AC20 PROFINET option requires configuration of both communication parameters and process data mapping.

8.1 Communication parameters

Keypad Menu Path	DSE-Lite Function Block	Webserver														
<pre> graph TD Setup[Setup] --> Communication[Communication] Communication --> Option[Option] </pre>	<pre> Option Comms Config COMMS FITTED NONE COMMS VERSION(0) 0 COMMS VERSION(1) 0 COMMS SERIAL NUM 0x00000000 COMMS STATE NONE DIAGNOSTIC OK EXCEPTION CODE 0x0000 COMMS SUPERVISED FALSE MAPPING CHANGED FALSE STATION NAME IP ADDRESS 0.0.0.0 SUBNET MASK 0.0.0.0 GATEWAY ADDRESS 0.0.0.0 ACTUAL BAUD RATE AUTO NONE EXTERNAL 0.0.0.0 0.0.0.0 0.0.0.0 0x001E 0 AUTO 19200 BPS EVEN 1 STOP FALSE 0 s TRUE COMMS REQUIRED ADDR ASSIGNMENT SET IP ADDRESS SET SUBNET MASK SET GATEWAY ADDR ACCESS NODE ADDRESS CANOPEN BAUD MODBUS BAUD RATE PARITY HIGH WORD FIRST ACTIVE TIMEOUT MASTERMAPPING </pre>	<p>Home ► Engineer ► Communications ► Option Comms</p> <table border="1"> <tr> <td>0691: Comms Required</td> <td>NONE</td> </tr> <tr> <td>0769: Comms Fitted</td> <td>UNKNOWN</td> </tr> <tr> <td>0770: Comms Version +</td> <td></td> </tr> <tr> <td>0773: Comms Serial Num</td> <td>00000000</td> </tr> <tr> <td>0774: Comms State</td> <td>NONE</td> </tr> <tr> <td>0775: Diagnostic</td> <td>OK</td> </tr> <tr> <td>0776: Exception Code</td> <td>0000</td> </tr> </table>	0691: Comms Required	NONE	0769: Comms Fitted	UNKNOWN	0770: Comms Version +		0773: Comms Serial Num	00000000	0774: Comms State	NONE	0775: Diagnostic	OK	0776: Exception Code	0000
0691: Comms Required	NONE															
0769: Comms Fitted	UNKNOWN															
0770: Comms Version +																
0773: Comms Serial Num	00000000															
0774: Comms State	NONE															
0775: Diagnostic	OK															
0776: Exception Code	0000															

The network parameters of the slave must be set to establish communication with master.

- The parameter **0691 COMMS REQUIRED** must be set to **PROFINET**.
- The parameter **0758 ADDRESS ASSIGNMENT** selects the slave IP Addressing method.
- There are three methods to set the IP address, subnet mask and gateway address of the device: the slave sets its own address, the address is set externally by a PROFINET master, or the address is set by a DHCP server.
- If the IP address is set by the slave (**Address Assignment = FIXED**) then three further parameters must be set:
 - 0759 SET IP ADDRESS**
 - 0760 SET SUBNET MASK**
 - 0761 SET GATEWAY ADDRESS**
- The parameter **0779 STATION NAME** must be set from a PROFINET master.
- The parameter **2566 MASTERMAPPING** must be set to choose how process data mapping will be defined. (See *Process Data Mapping* for detail)
- The parameter **0762 ACCESS** may be set to enable web features of the AC20 option comms (IP Config Enable, Web Enable, Web Parameters Enable, FTP Enable, FTP Admin Mode).

Configuration with DSE Lite

When performing an online configuration, the fitted option card will automatically be selected. In offline mode, display your configuration page in DSE Lite and click the plus sign [+] at the left of function block **Option Comms Config** to see set communication parameters.

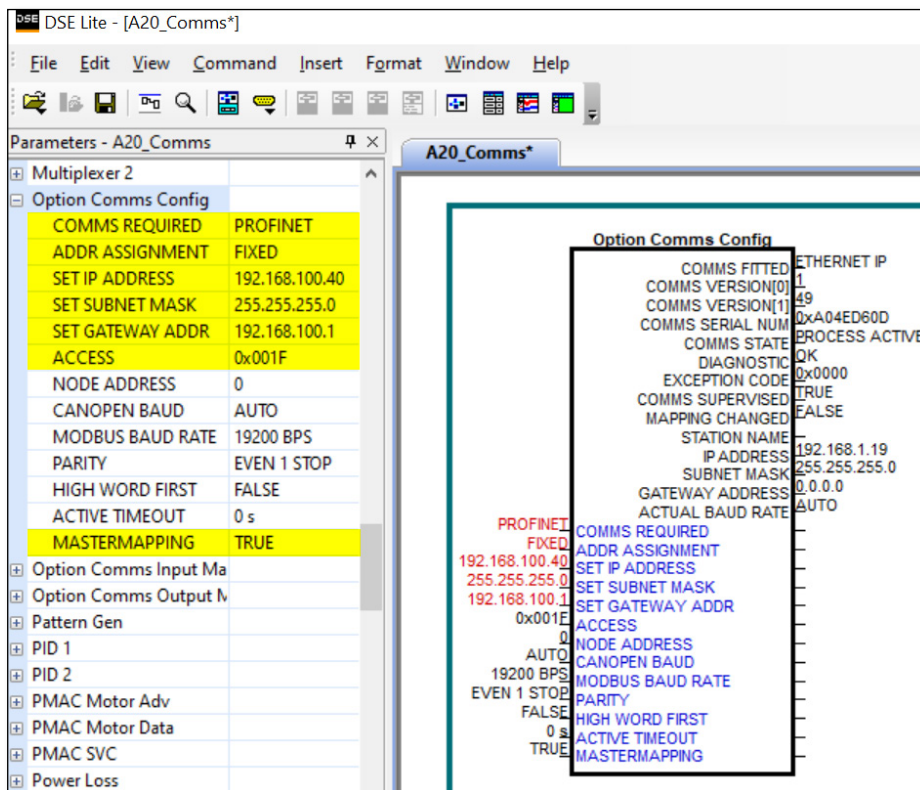

Alternatively, perform the steps described above by double clicking on the function block **Option comms config** to open parameters tab in the configuration interface.

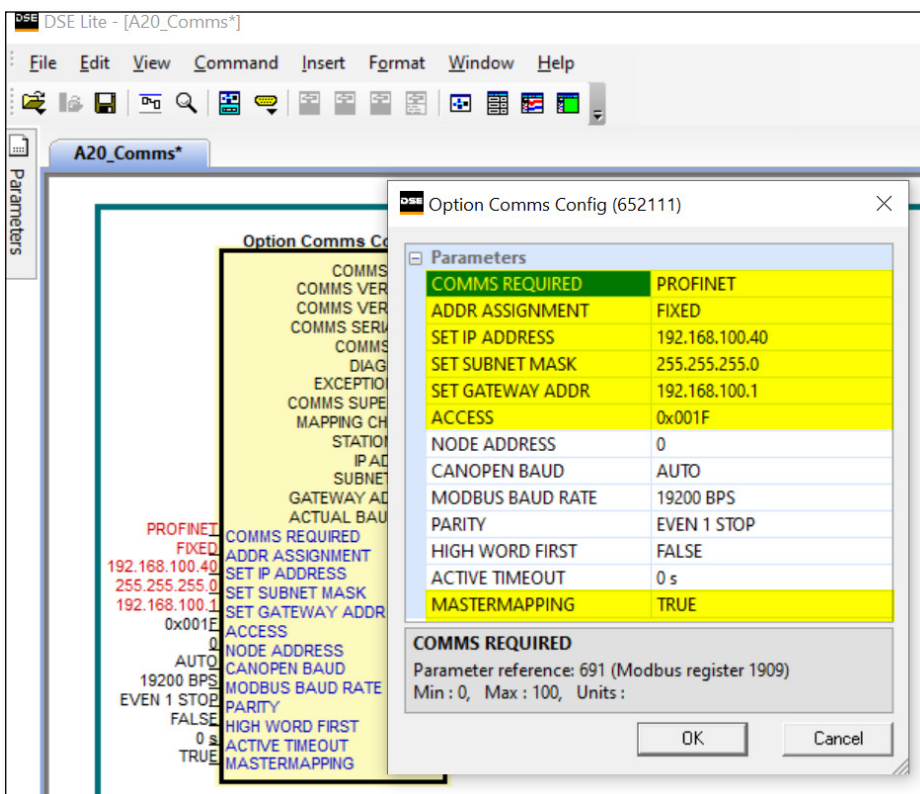

Configuration with the webserver

Access the AC20 webserver by typing the IP-Address of the drive into the web browser.

The drive must be in configuration state. Set the PROFINET Option comms parameters as shown below.

AC20 Webserver view when Master mapping is TRUE

The screenshot shows the Parker webserver interface. The user is logged in as 'ENGINEER'. The navigation path is 'Home > Engineer > Communications > Option Comms'. The 'State' is 'Configuration' and the 'Drive' is 'OK'. The 'Comms Required' parameter is set to 'PROFINET'. The 'MasterMapping' parameter is checked, indicating it is TRUE. Other parameters include 'InMappingStatus', 'OutMappingStatus', 'Addr Assignment' (FIXED), 'Set IP Address' (192.168.100.40), 'Set Subnet Mask' (255.255.255.0), 'Set Gateway Addr' (0.0.0.0), and 'Access' (001F).

AC20 Webserver view when Master mapping is FALSE

The screenshot shows the Parker webserver interface. The user is logged in as 'ENGINEER'. The navigation path is 'Home > Engineer > Communications > Option Comms'. The 'State' is 'Configuration' and the 'Drive' is 'OK'. The 'Comms Required' parameter is set to 'PROFINET'. The 'MasterMapping' parameter is unchecked, indicating it is FALSE. Other parameters include 'Input Mapping', 'Out Mapping', 'Addr Assignment' (FIXED), 'Set IP Address' (192.168.100.40), 'Set Subnet Mask' (255.255.255.0), 'Set Gateway Addr' (192.168.100.1), and 'Access' (001F).

Device Name

The AC20 option comms slave requires a device (station) name to be assigned. This must be done by the PROFINET master.

8.2 Process Data

AC20 parameters implementation

The AC20 PROFINET option requires configuration of **process data mapping**.

Config Mapping

There are two methods to define process data mapping: the process data will be mapped **using the AC20 input and output mapping tables** or **from the PLC**.

The parameter **2566 MASTERMAPPING** defined the method; If FALSE the AC20 input and output mapping tables will be used to configure process data mapping, If TRUE the bus master set/configures the Process data mapping and AC20 input and output mapping tables will be cleared.

Set process data using AC20 input and output mapping tables

These tables are two parameter arrays in which AC20 parameter numbers may be added. The parameter **2566 MASTERMAPPING** must be set to **FALSE**. The tables can be accessed via Keypad, via DSE Lite application and via webserver.

Read Mapping:

The read process data represents cyclic data sent from the PLC to the AC20, this is mapped into the table **Option Comms Input Mapping**. Only writable AC20 parameters that are not configuration parameters may be added to the read process data.



Keypad Menu Path	DSE Lite Function Block	Webserver
<pre> graph TD Engineer --> Communications Communications --> OptionComms[Option Comms] OptionComms --> InputMapping[Input Mapping[]] </pre>		

Write Mapping:

The write process data represents cyclic data sent from the AC20 to the PLC, this is mapped into the table **Option Comms Output Mapping**.



Keypad Menu Path	DSE Lite Function Block	Webserver

Note: *String-type parameters cannot be mapped.*

Set process data from PROFINET master

The GSDML file defines a number of modules. Each module corresponds to an AC20 parameter, when configuring the PLC, the modules may be added to the slave device slots as required. These modules map to the process data in the order in which they are added.

The parameter **2566 MASTERMAPPING** must be set to **TRUE** and this will auto reset the AC20 input and output mapping.

Cyclic Data Exchange

Cyclic data exchange will occur when a connection is established either in RUN mode (PROCESS ACTIVE) or STOP mode (IDLE). However, the read process data will only update the mapped parameters when in the PROCESS ACTIVE mode.

On a transition into the PROCESS ACTIVE state all read process mapped parameters will be updated. When in the PROCESS ACTIVE state, the read process mapped parameters will all update only when a change in the read process data occurs.

Mapping status

The process data mapping status can be accessed from AC20 via the following parameters:

- Parameter **2586 InMappingStatus**: shows the status of the currently active cyclic data input mapping table (32 entries), value is the Tag ID of the parameter to be cyclic read In.
- Parameters **2619 OutMappingStatus**: Shows the status of the currently active cyclic data output mapping table (32 entries), value is the Tag ID of the parameter to be cyclic sent out.

The parameters **2586 InMappingStatus** and **2619 OutMappingStatus** are visible from the webserver and are valid if **Parameter 0774 Comms State** = PROCESS ACTIVE and parameter **2566 MasterMapping** = TRUE.

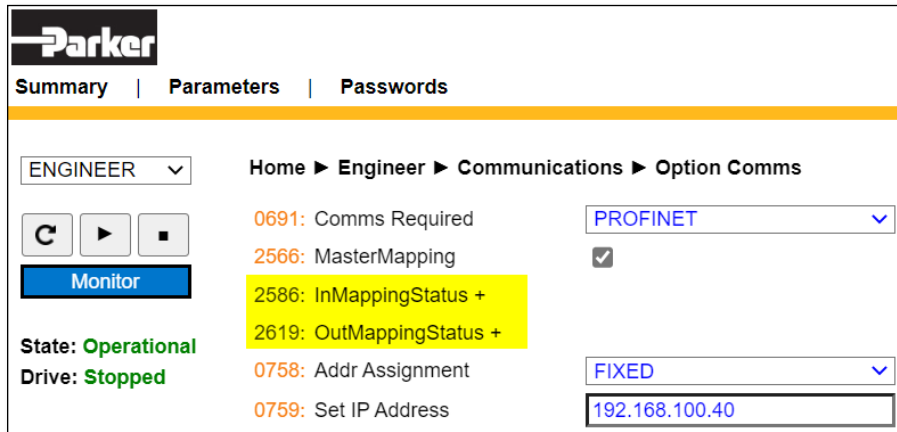

8.3 Acyclic Data Exchange

AC20 parameters may be accessed acyclically from the network using Record Data read / write services. If addressed through a given API (Application Process Instance) and Index range, the module translates the service into standard object requests towards the Application Data Object.

The AC20 parameters may be accessed via Application Process Instance zero (API 0). Slot 0, Subslot 1 may be used.

- There is a 1:1 correlation between the index and the parameter number.
- Parameter arrays may be accessed, either as a whole or as individual elements.
- Index 0 (zero) is not associated with a parameter and cannot be used

8.4 PROFINET GSDML File

The GSDML device description file holds a description of the device and its functions. Most important the file describes the parameters implementation in the module. GSDML file for the AC20 PROFINET option may be downloaded from the AC20 product page at www.parker.com

9 Example Configuration and Programming

9.1 AC20 Motor Control Application

Use DSE Lite to create, parameterize and configure user defined applications or parameterize and connect fixed motor control blocks in the application. Download the application into the drive then connect to the PLC to read/write the value of the parameters.

In the example below the PLC is used to set motor speed and control, then to read the speed feedback, status of the control and speed reference.

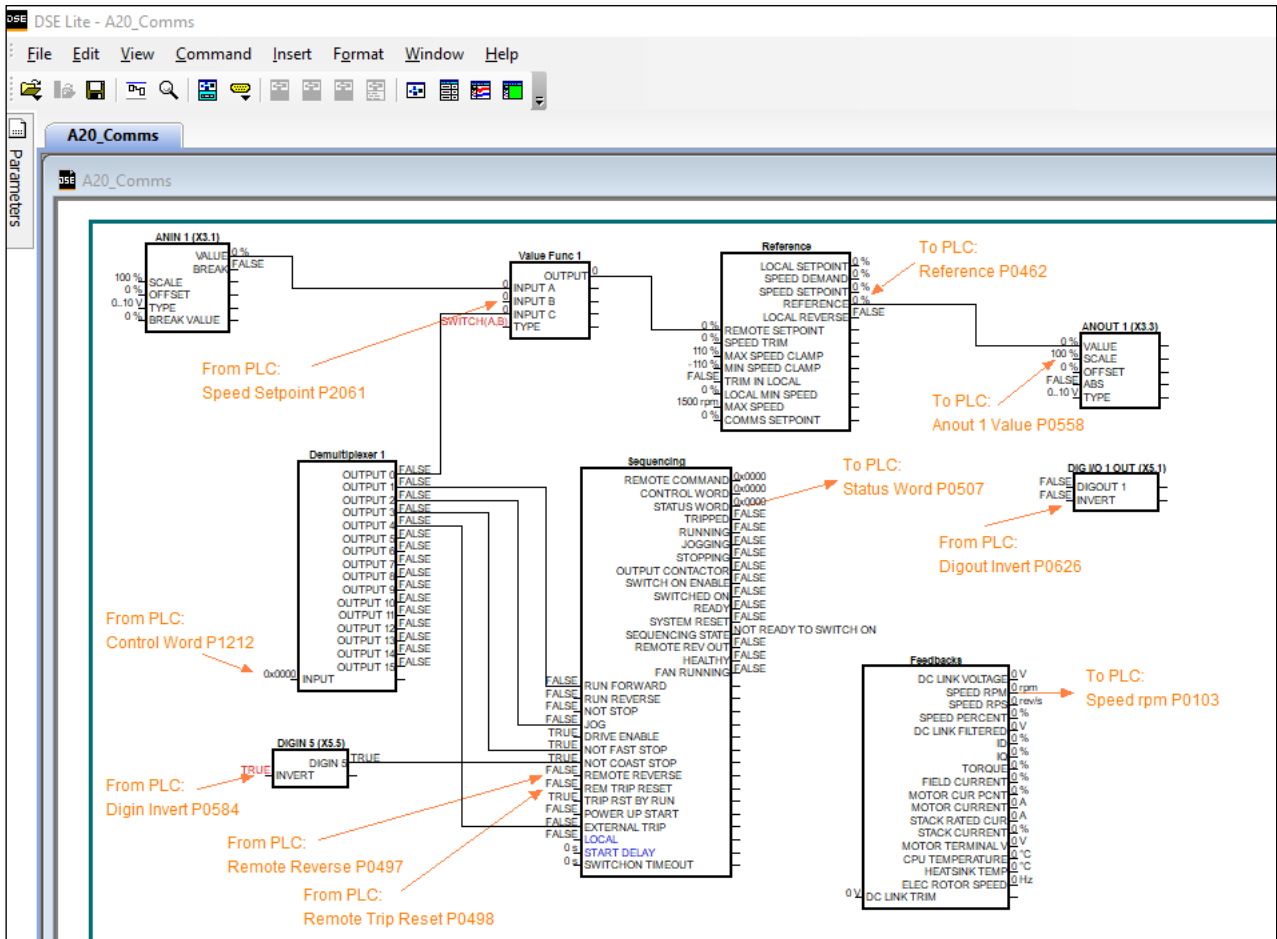

The data highlighted will be mapped into the AC20 process data mapping table in the example below.

9.2 List of process data

Read / Write Process Data mapping list for master/PLC

AC20 Input Mapping	Data Type	Comments	PLC Module
1212 Input Demultiplexer 1	WORD	Control Word	Output
2061 Input B Value Func 1	REAL	Speed Setpoint	
0584 Digin Invert	WORD	Invert digital input	
0626 Digout Invert	WORD	Invert digital Output	
0497 Remote reverse	BOOL	Invert motor Rotation	
0498 Rem Trip Reset	BOOL	Trip Reset	

AC20 Output Mapping	Data Type	Comments	PLC Module
0507 Status Word	WORD	Status Word	Input
0462 Reference	REAL	Speed Reference	
0103 Speed rpm	REAL	Speed Feedback	
0534 Anin1 Value	REAL	Analog In1 Value	
0540 Anin2 Value	REAL	Analog In2 Value	
0558 Anout1 Value	REAL	Analog Out1 Value	
0563 Anout2 Value	REAL	Analog Out2 Value	
0610 Digin Word	WORD	Digital Input state	
0625 Digout Word	WORD	Digital Output state	

9.3 Programming with Siemens PLC

The example uses Siemens S7-1212C as controller PLC and Tia Portal V14 as programming Environment. Prior knowledge of TIA Portal software is assumed.

Create a project

- Launch the Tia portal software from desktop then click **Start** and select **Create new project**. Define project properties and click on **Create**.

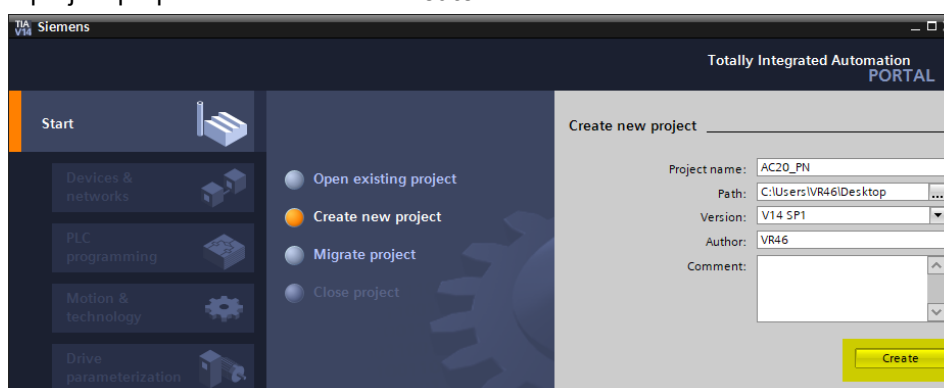

Add Controller (PLC)

- Click on **Devices & networks**, select **Add new device**, select your controller from catalog then click on **Add** to insert the PLC into the project.

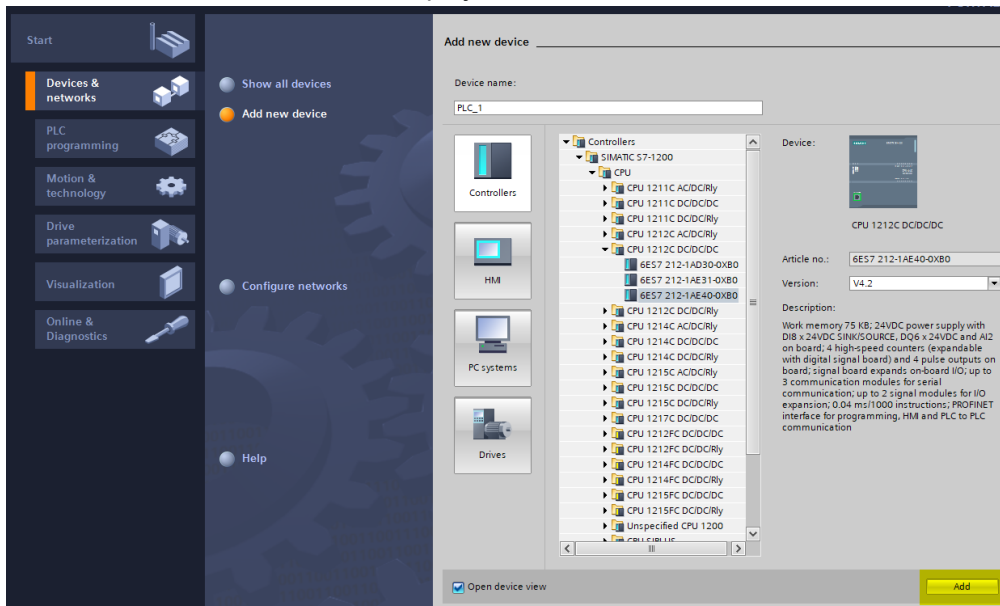

- From the **Devices & Networks** view select the controller, then click on properties to set the **controller network interface**, the **IP address** and other parameters.

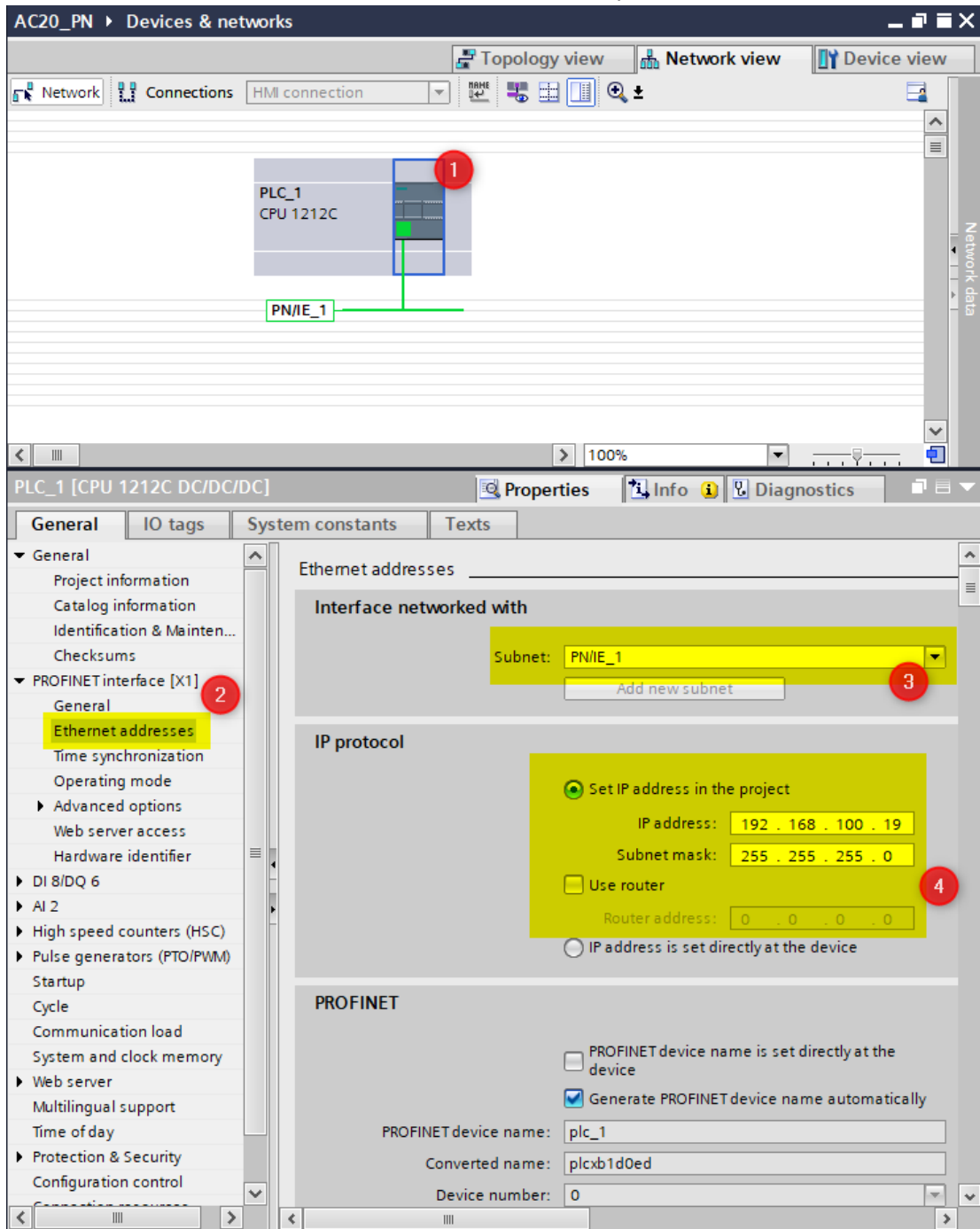

GSDML File installation

- From the Tia portal menu bar click on **Options > Manage general station description files (GSD)** to open the tab.

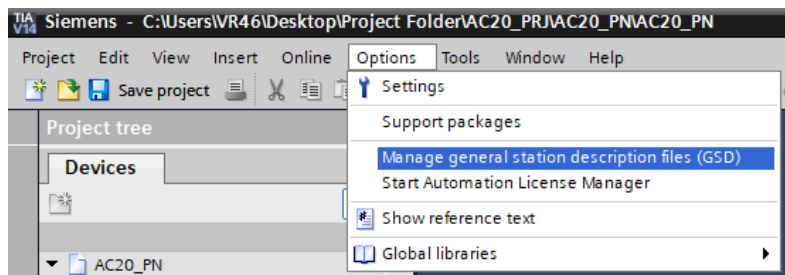

- Click on **source path** to select the folder where the file description is stored.
- Select GSDML file then click on **install**.

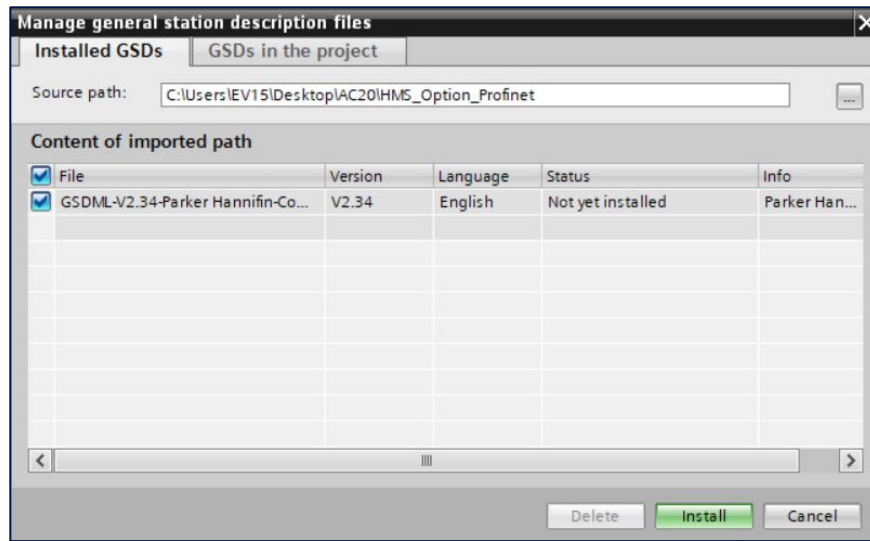

- The slave will then become available in Tia portal hardware catalogue.

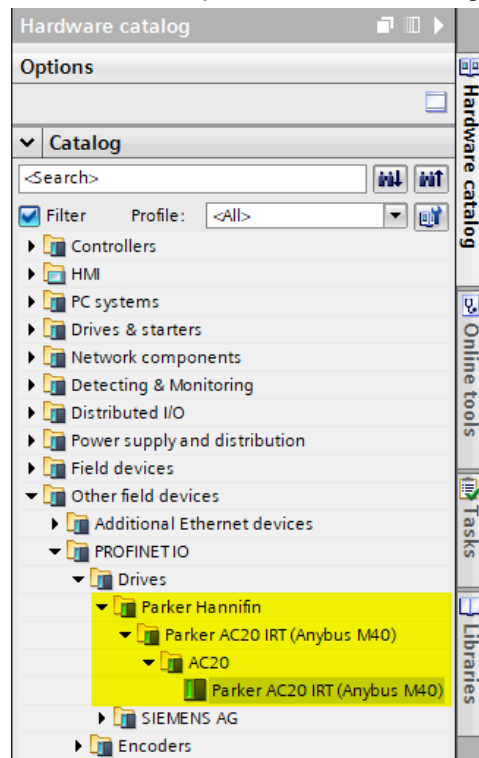

Add AC20 PROFINET Device

- Drag and drop the slave from **Hardware Catalogue** to **Network View**.

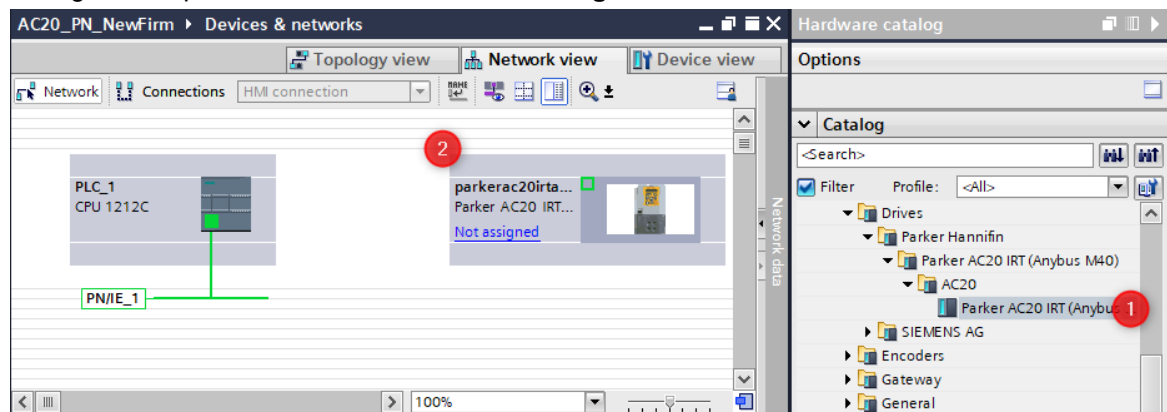

- From the **Devices & network** view select AC20 slave, click on **properties** to expand the tab then select **network interface** to define **station name**, **IP Address** and **subnet mask**.

The screenshot displays the SIMATIC Manager interface for configuring a Parker AC20 IRT device. The top window shows a network diagram with a PLC_1 CPU 1212C connected to a Parker AC20 IRT device via a PN/IE_1 interface. The bottom window shows the 'Properties' dialog for the device, with the 'Ethernet addresses' tab selected. The 'Interface networked with' dropdown is set to 'PN/IE_1'. The 'IP protocol' section has 'Set IP address in the project' selected, with IP address '192.168.100.40' and subnet mask '255.255.255.0'. The 'PROFINET' section has 'Generate PROFINET device name automatically' checked, with device name 'parkerac20irtanybusm40'.

Configure Process Data Mapping

Option 1: Using AC20 Input and output mapping tables

- The parameter **2566 MASTERMAPPING** must be set to **FALSE** to prevent the PLC from overwriting the mapping.
- Through the mapping tables from the keypad, DSE Lite or Webserver, add parameter numbers into the appropriate table.

Option Comms Input Mapping		Option Comms Output Mapping	
1212	MAPPING[0]	507	MAPPING[0]
2061	MAPPING[1]	462	MAPPING[1]
584	MAPPING[2]	103	MAPPING[2]
626	MAPPING[3]	534	MAPPING[3]
497	MAPPING[4]	540	MAPPING[4]
498	MAPPING[5]	558	MAPPING[5]
0	MAPPING[6]	563	MAPPING[6]
0	MAPPING[7]	610	MAPPING[7]
0	MAPPING[8]	625	MAPPING[8]
0	MAPPING[9]	0	MAPPING[9]
0	MAPPING[10]	0	MAPPING[10]
0	MAPPING[11]	0	MAPPING[11]
0	MAPPING[12]	0	MAPPING[12]
0	MAPPING[13]	0	MAPPING[13]
0	MAPPING[14]	0	MAPPING[14]
0	MAPPING[15]	0	MAPPING[15]
0	MAPPING[16]	0	MAPPING[16]
0	MAPPING[17]	0	MAPPING[17]
0	MAPPING[18]	0	MAPPING[18]
0	MAPPING[19]	0	MAPPING[19]
0	MAPPING[20]	0	MAPPING[20]
0	MAPPING[21]	0	MAPPING[21]
0	MAPPING[22]	0	MAPPING[22]
0	MAPPING[23]	0	MAPPING[23]
0	MAPPING[24]	0	MAPPING[24]
0	MAPPING[25]	0	MAPPING[25]
0	MAPPING[26]	0	MAPPING[26]
0	MAPPING[27]	0	MAPPING[27]
0	MAPPING[28]	0	MAPPING[28]
0	MAPPING[29]	0	MAPPING[29]
0	MAPPING[30]	0	MAPPING[30]
0	MAPPING[31]	0	MAPPING[31]

Note: If the first row of a table (input mapping or Output mapping) is empty or equal to 0, the table will not be accessible and configurable from PLC.

- In Tia portal drag and drop the appropriate input and output modules from device catalogue to the AC20 slot then define the variable name.

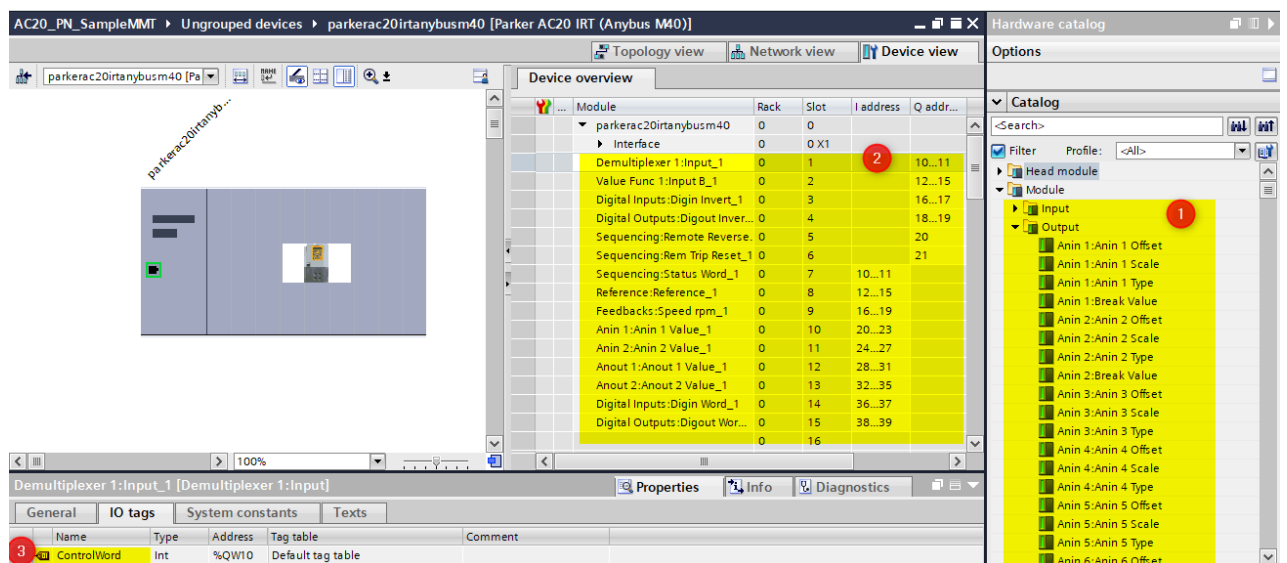

Option 2: From PLC

- The parameter **2566 MASTERMAPPING** must be set to **TRUE**.
- By selecting the slave, the input and output process data may be configured. The appropriate input and output modules may be dragged from the catalogue and dropped into the appropriate slot.
- Set the I/O address of each module then assign a name to the module variable. Each module corresponds to a drive parameter. (See step 2 of the description for Option 1)

Note: The AC20 Input/Output mapping table will be set to zero and will not have effect in this configuration.

Create a program to transfer data

In the example ladder code below, in Network 1 the data is read from drive to PLC and in Network 2 the PLC writes data to the drive.

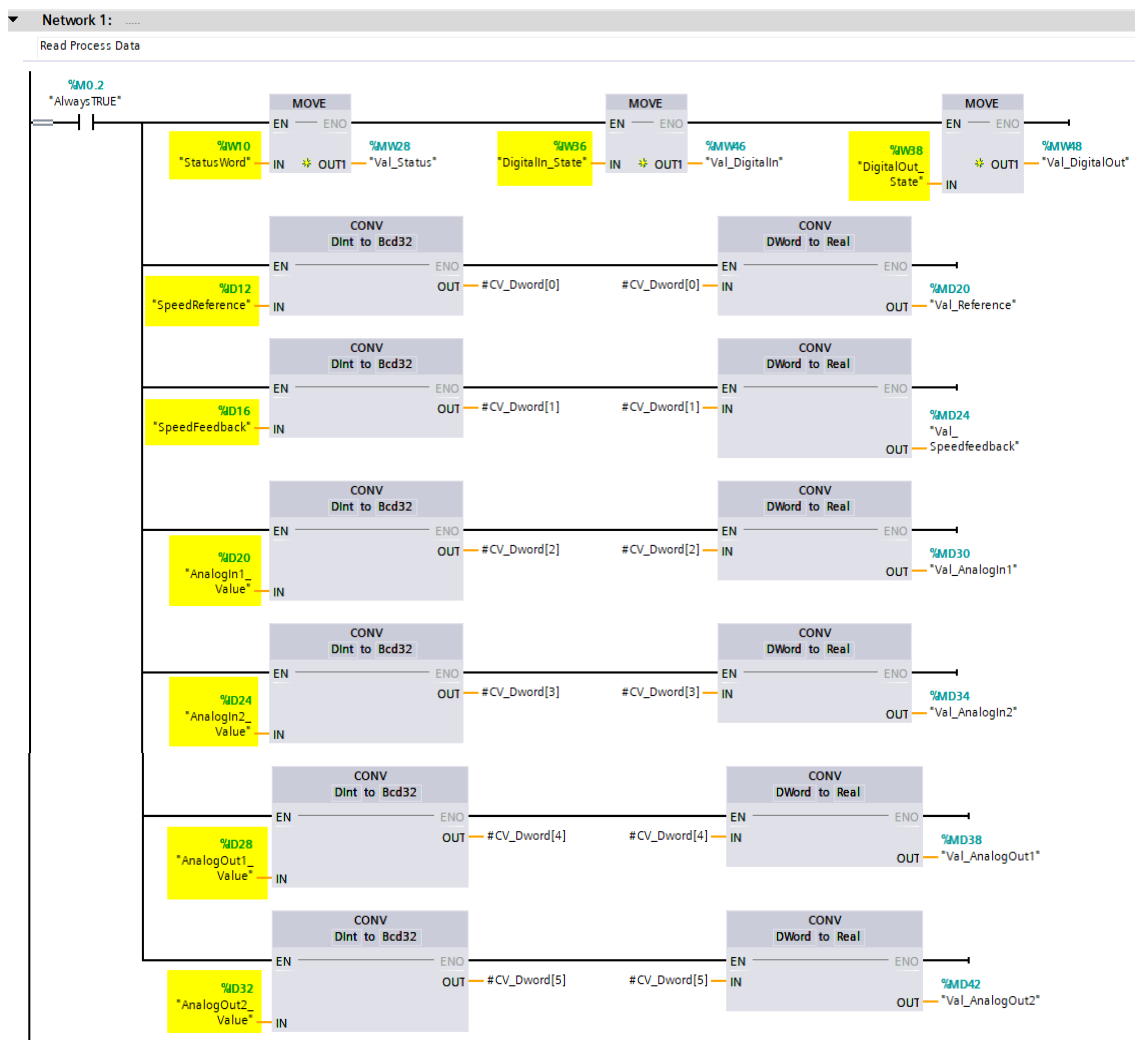

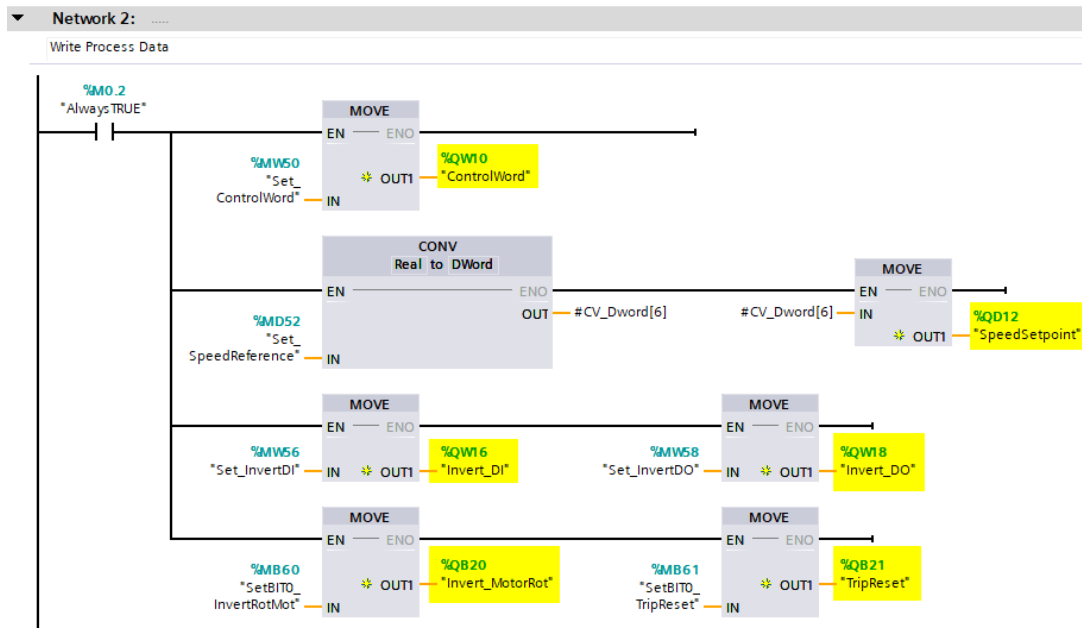

Set IP Address and Device name of to the physical device

- Make sure the PC, PLC, and AC20 PROFINET module are physically connected.
- In Tia portal, from the **Go online** Tab, set PG/PC interface, start search, select found device.
- Click on **Go online**.

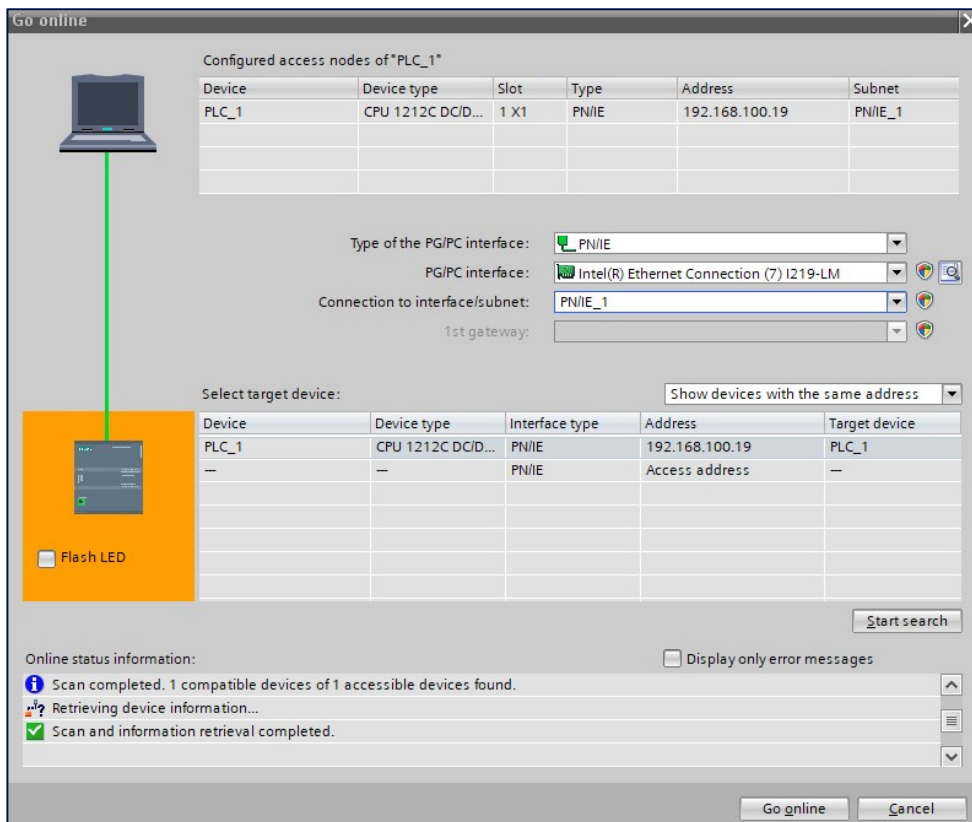

- From “Devices & network” view, right click slave and select “Online diagnostic” for device configuration

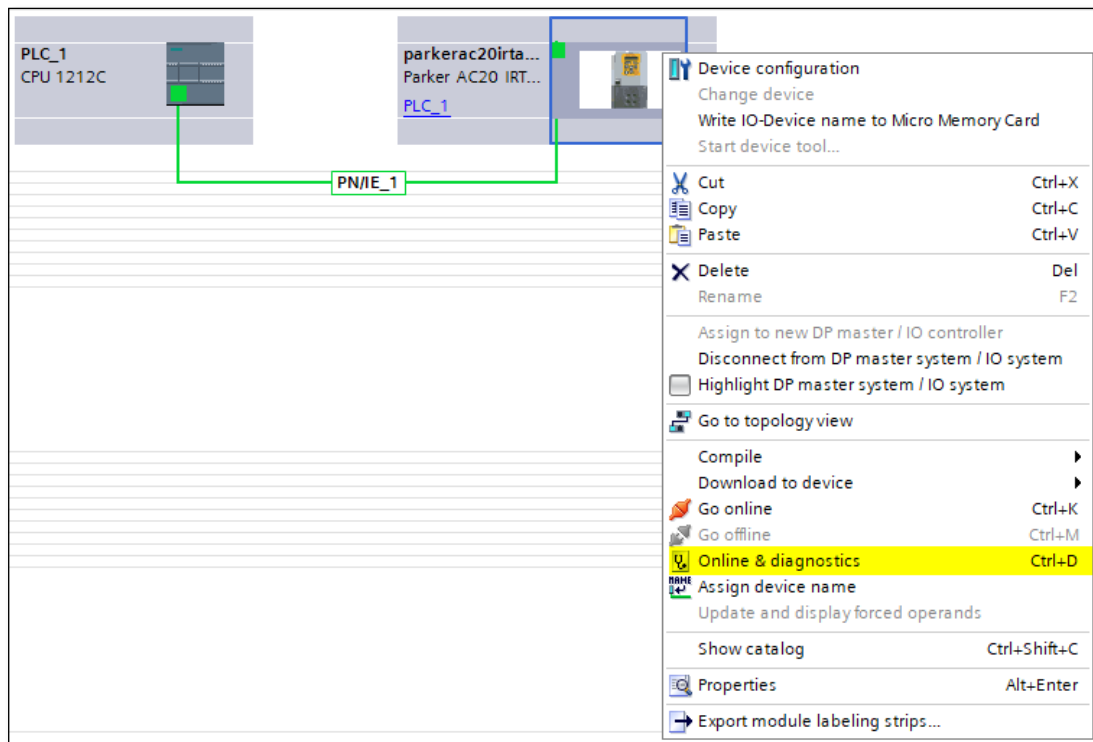

- From **Online & diagnostics** view, click on **Assign IP Address**.
- Click **Accessible devices** to search slave online according to its MAC Address then click on **Assign IP Address** to set the IP address of the physical slave.

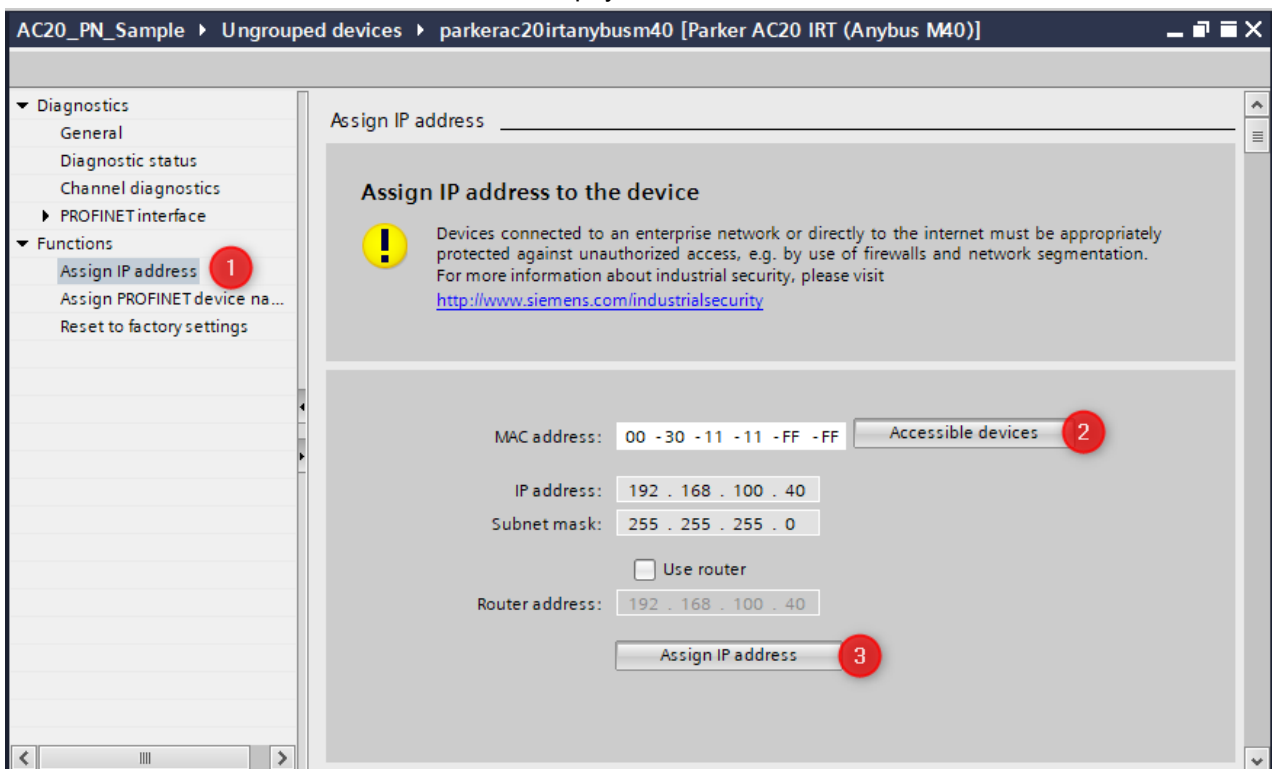

- Select **Assign PROFINET device name** to open the view, click on **Update list** to search slave online, then click on **Assign name** to set slave name.

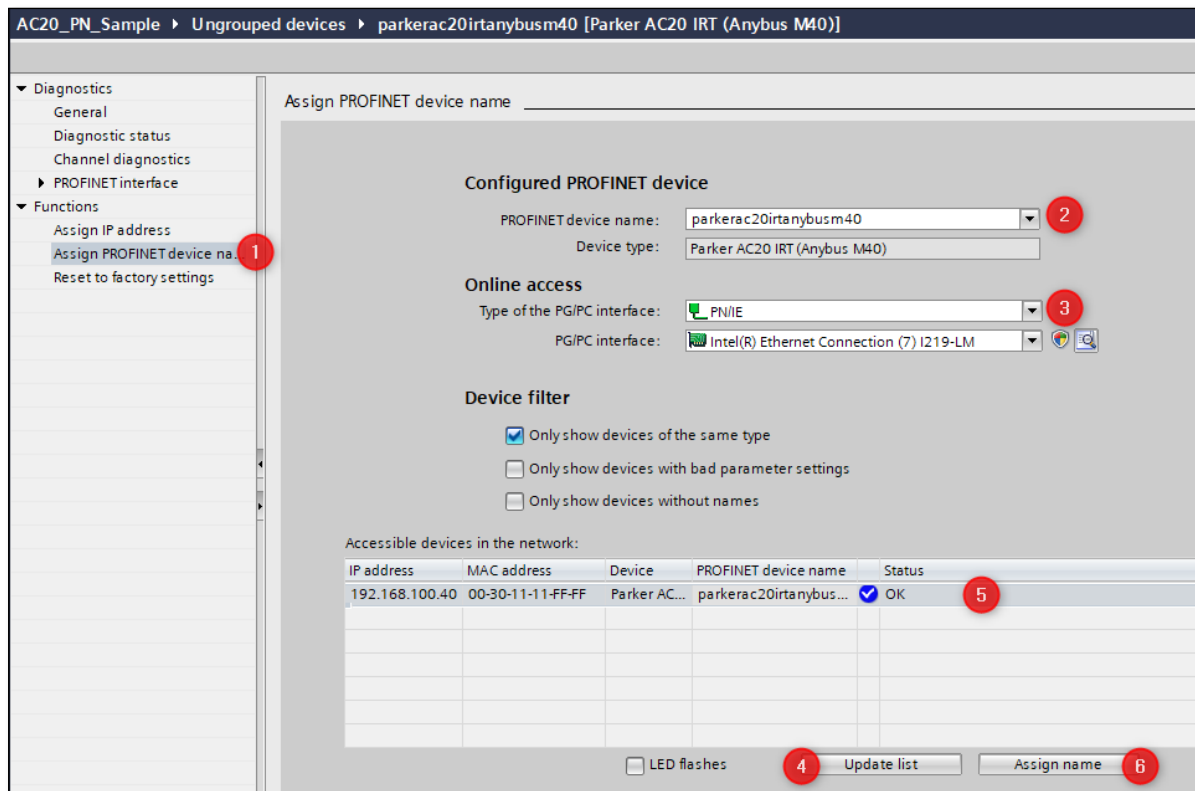

Read / Write parameters Acyclically

AC20 parameters data may be accessed via acyclic communication using PROFINET. The acyclic read and write services may be achieved using functions block “**RDREC**” and “**WRREC**” on Tia portal environment. The input “**Index**” corresponds to the parameter number and the “**ID**” corresponds to the Hardware Identifier of the Option Comms module.

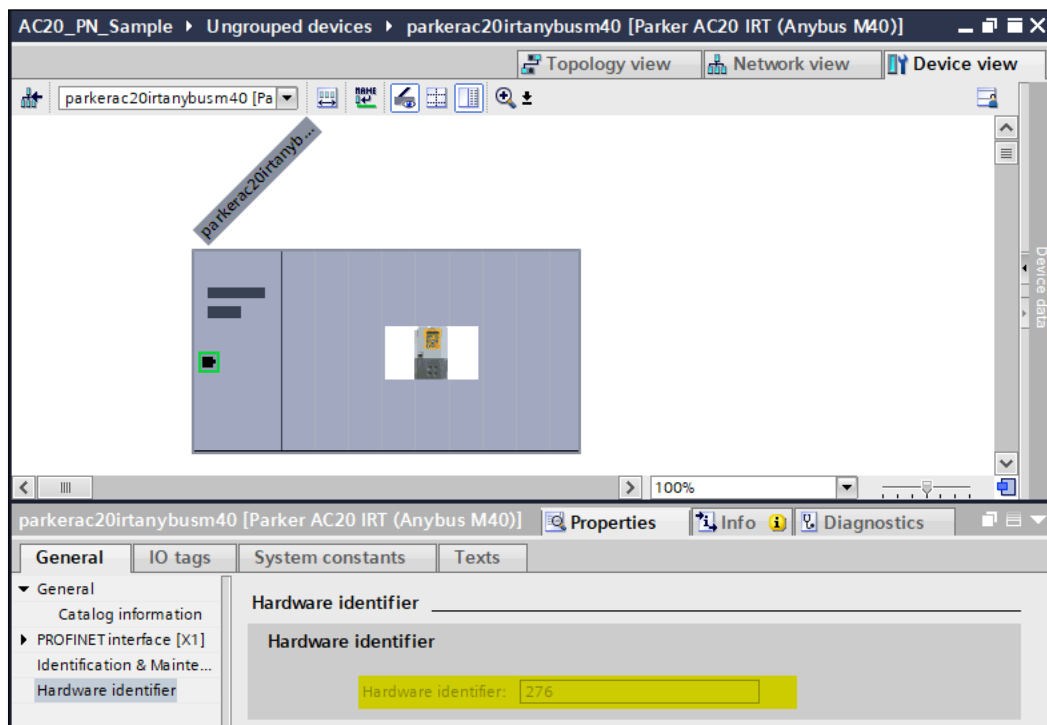

- Example: Read parameter **0056 Current Limit Out** (2038h).
- The “RDREC” function block is used to send acyclic read requests to the AC20, as well as receive the requested response.

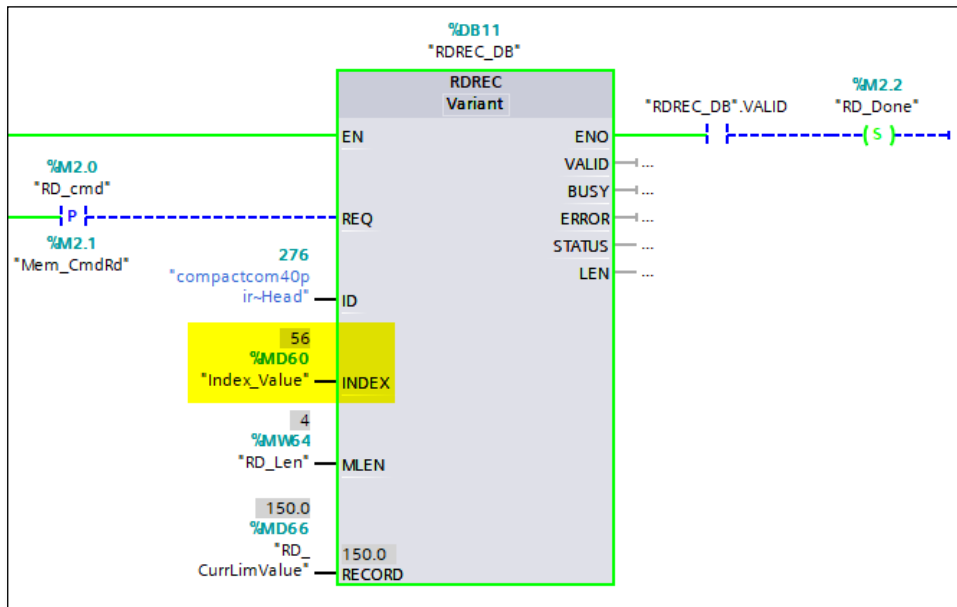

Parameter	Data Type	Description
MLEN	UINT	Parameter length to read
RECORD	VARIANT	Target area for the value of the parameter read

- Example: Write parameter **0457 Motor Max Speed** (21C9h).
- The “WRREC” function block is used to send acyclic write request to the AC20, as well as receive the requested response.

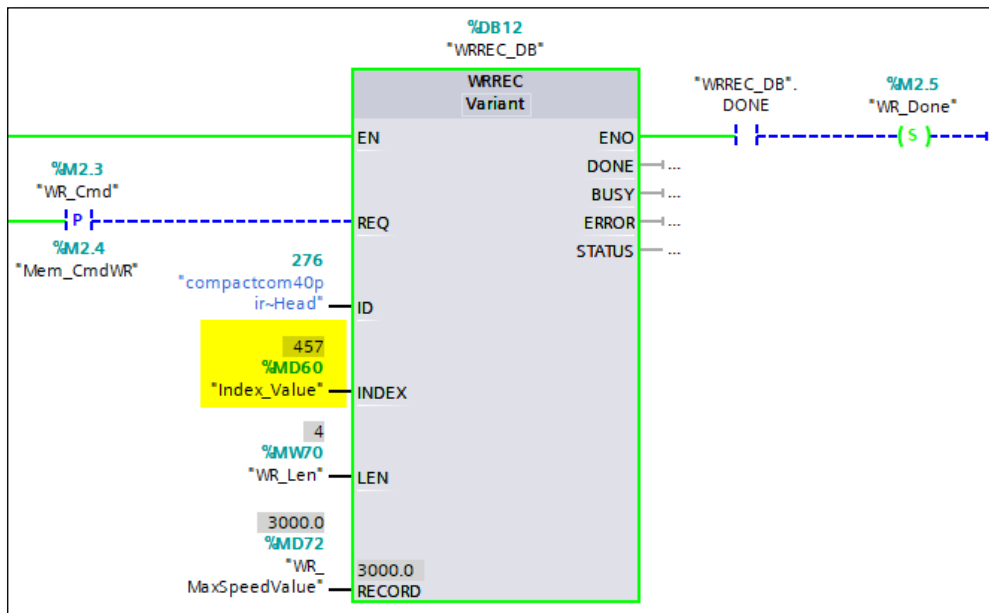

Parameter	Data Type	Description
MLEN	UINT	Parameter length
RECORD	VARIANT	Source area for the value of the parameter to be written

10 Option Module Webserver

The option comms module built-in webserver provides a flexible environment for end-user interaction configuration purposes, parameters setting and diagnostics.

- The parameter **0762 “ACCESS”** BIT0 “**IP CONFIG ENABLE**”, BIT1 “**WEB ENABLE**” and BIT2 “**WEB PARAMETERS ENABLE**” must be set to **TRUE** via the AC20 webserver or DSE Lite.

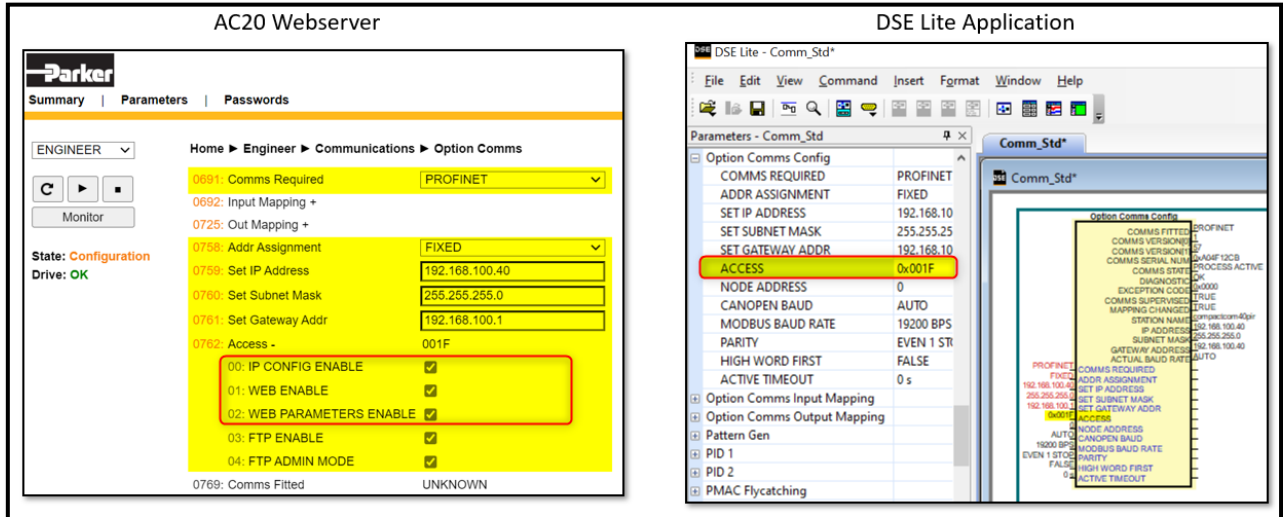

- The web pages may be accessed by a web browser by entering the IP address of the AC20 Ethernet/IP option comms module. The main index page provides access to network configuration parameters, network status information and access to the AC20 Parameters.

Network Configuration parameters

The network configuration page provides interfaces for changing TCP/IP and SMTP settings. The module needs a reset for the changes to take effect.

TCP/IP settings

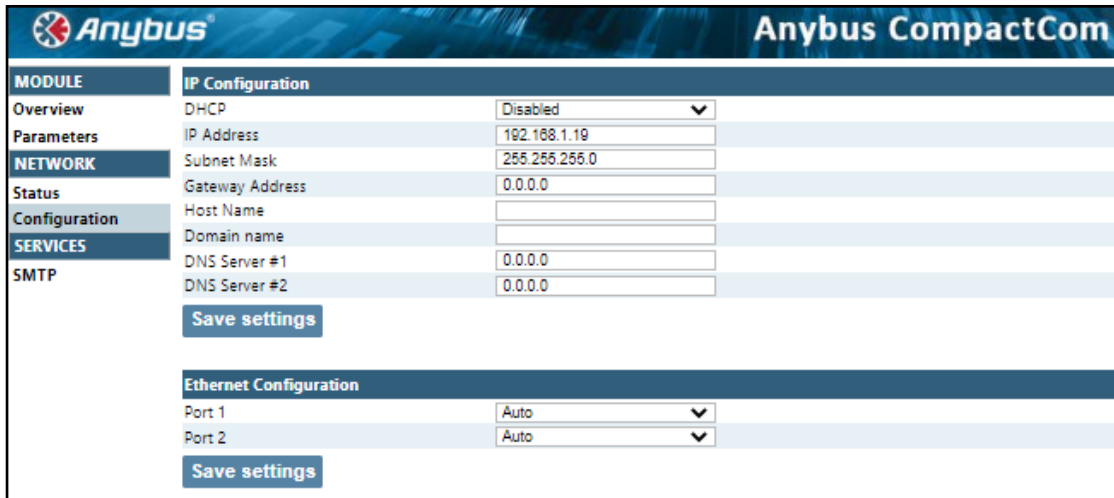

The screenshot shows the 'Anybus CompactCom' web interface. On the left, a navigation menu lists 'MODULE', 'Overview', 'Parameters', 'NETWORK', 'Status', 'Configuration', 'SERVICES', and 'SMTP'. The main content area is titled 'IP Configuration' and includes the following fields:

- DHCP: Disabled (dropdown menu)
- IP Address: 192.168.1.19
- Subnet Mask: 255.255.255.0
- Gateway Address: 0.0.0.0
- Host Name: (empty text box)
- Domain name: (empty text box)
- DNS Server #1: 0.0.0.0
- DNS Server #2: 0.0.0.0

Below these fields is a 'Save settings' button. Further down, the 'Ethernet Configuration' section includes:

- Port 1: Auto (dropdown menu)
- Port 2: Auto (dropdown menu)

A second 'Save settings' button is located at the bottom of the Ethernet Configuration section.

SMTP (Simple Mail Transfer Protocol) settings

The built-in email client can send predefined email messages based on trigger-events in the dual port memory (DPRAM). The module needs a valid SMTP server configuration in order to be able to send email messages.

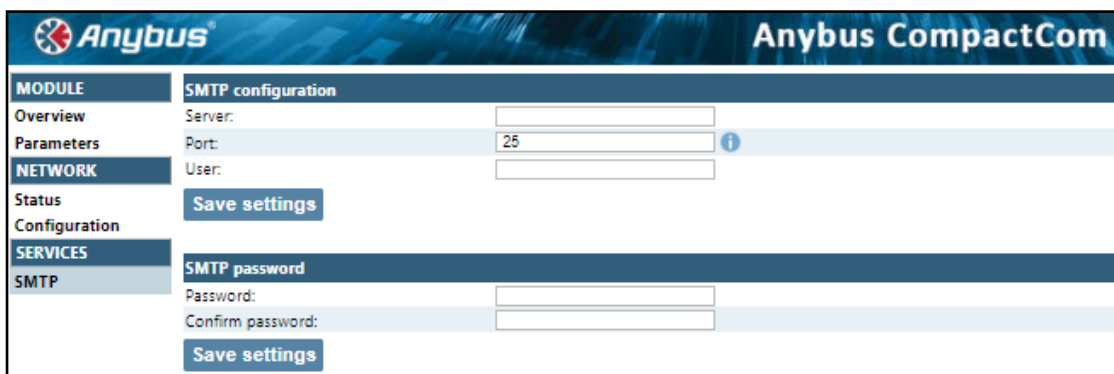

The screenshot shows the 'Anybus CompactCom' web interface. On the left, the navigation menu is the same as in the previous screenshot. The main content area is titled 'SMTP configuration' and includes the following fields:

- Server: (empty text box)
- Port: 25 (text box with an information icon to its right)
- User: (empty text box)

A 'Save settings' button is located below these fields. Below this, the 'SMTP password' section includes:

- Password: (empty text box)
- Confirm password: (empty text box)

A second 'Save settings' button is located at the bottom of the SMTP password section.

Network status information

The Network Status page provides information about the Ethernet ports and communications statistics.

MODULE	Current IP Settings	
Overview	DHCP:	Disabled
Parameters	IP Address:	192.168.1.19
NETWORK	Subnet Mask:	255.255.255.0
Status	Gateway Address:	0.0.0.0
Configuration	Host Name:	
SERVICES	Domain name:	
SMTP	DNS Server #1:	0.0.0.0
	DNS Server #2:	0.0.0.0

Current Ethernet Status	
MAC Address:	00:30:11:11:FF:FF
Port 1:	No Link
Port 2:	100 FDX

- ▶ Interface Counters
- ▶ Media Counters
- ▼ EtherNet/IP Statistics

EtherNet/IP Statistics	
Established Class1 Connections:	0
Established Class3 Connections:	0
Connection Open Request:	0
Connection Open Format Rejects:	0
Connection Open Resource Rejects:	0
Connection Open Other Rejects:	0
Connection Close Requests:	0
Connection Close Format Rejects:	0
Connection Other Rejects :	0
Connection Timeouts :	0

AC20 Parameters Data

The Parameter Data pages allow access to AC20 parameters. To enable access to this page the parameter **0762 “ACCESS” BIT2 Web Parameters Enable** must be set to TRUE.

During the setting, the value of the parameter is written into the column value, the button “set” change from gray to blue, this button should be pressed to apply the parameter change.

MODULE	#	Name	Value	Set
Overview	1	Customise Menus:Language	ENGLISH	Set
Parameters	2	Keypad:View Level	TECHNICIAN	Set
NETWORK	3	Keypad:KPad/DSE Passwrd		Set
Status	10	Web Server:Web Access	FULL	Set
Configuration	11	Fast Trace:Enable	<input type="checkbox"/>	Set
SERVICES	12	Fast Trace:No Of Channels	7	Set
SMTP	13	Fast Trace:Channel Addr	0: 460	Set
			1: 105	Set

11 FTP Server

FTP (File Transfer Protocol) Server

The option has a built-in FTP server enabling access to the FLASH based file system.

The FTP server must be enabling by setting parameter **0762 "ACCESS"** BIT3 "FTP ENABLE" and BIT4 "FTP ADMIN MODE" to TRUE.

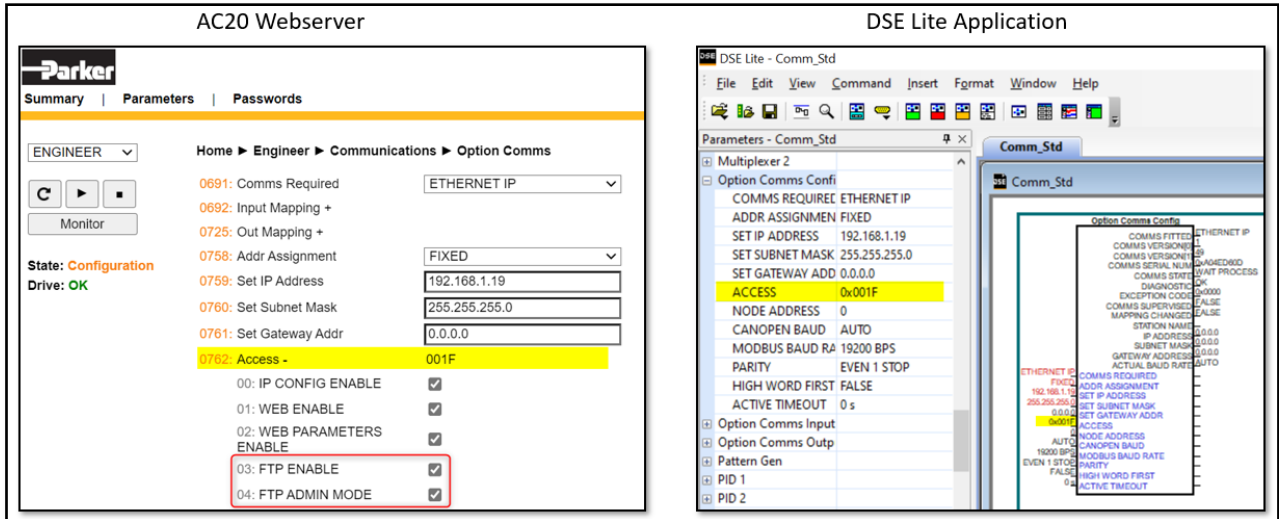

To access the file system an FTP client is required such as Windows Explorer. Enter the IP address into the address bar, for example ftp://192.168.1.19 By default no files are stored on the file system (the built-in web files are virtual files).

12 Lost Communication Trip

Supervised Parameter:

The **0777 Comms Supervised** parameter indicates that the PROFINET network participation is supervised by another PROFINET device.

The Supervised parameter value is set to TRUE when one or more IO connections have been opened are established.

The Supervised parameter will subsequently change to FALSE if the connection is closed or the PROFINET watchdog has timed out.

Comms Break Trip

The drive will trip when there is a loss of communications between the master and the drive.

A COMMS BREAK trip will occur if the **0777 Comms Supervised** parameter transitions from TRUE to FALSE and the drive is in the operational state.

The trip may be disabled by clearing the respective bit in the parameter **0870 Enable Trips Lo**. The parameter Enable Trip Lo is a 32-bit word, the bit number 27 is used to disable or to enable the trip.

Comms state

The parameter **0774 Comms State** indicates 'PROCESS_ACTIVE' when the PROFINET communication is active. The table below describes how the comms state relates to the PROFINET network:

Comms State	Comments
WAIT_PROCESS	The slave stays in this state until an IO connection with an IO controller is opened.
ERROR	Duplicate IP address detected, communication lost, Configuration data mismatch or initial parameter error
PROCESS_ACTIVE	IO Connection established
IDLE	IO controller with which an IO connection is established is in STOP mode
EXCEPTION	Unexpected error: turn module status LED red, to indicate major fault, turn network status LED off and hold Ethernet MAC in reset

13 Diagnostic Event

Configuration problems can often be identified by looking at the Run and Error LEDs and from the Comms Diagnostic **0775 parameters**. Under normal operating conditions the Comms diagnostic parameter should indicate **OK**. Other values are summarized in the Diagnostic Parameters section.

Hardware Mismatch

Diagnostic = HARDWARE MISMATCH:

The required option does not match the actual fitted option.

No option is fitted but one is required.

Invalid Configuration

Diagnostic = INVALID CONFIGURATION:

Invalid read or write process data mapping

Invalid communication settings

Diagnostic = MAPPING FAILED:

Attempting to map a parameter that does not exist.

Attempting to map a configuration parameter.

Attempting to map a read-only parameter to the read process data.

Other Diagnostics

Diagnostic = EXCEPTION :

Module has gone into an unrecoverable exception state

Diagnostic = UNSUPPORTED OPTION:

The fitted option is not supported by the drive

Diagnostic = NOT RESPONDING:

no initial response from the option

APPENDIX A: Data types

The relationship between AC20 parameter and PROFINET data type is given in the table below.

AC20 Parameter		CIP	
Data Type	Description	Data Type	Bytes
BOOL	Boolean	BOOL	1
SINT	Short integer	SINT	1
INT	Integer	INT	2
DINT	Double integer	DINT	4
USINT	Unsigned short integer	USINT	1
UINT	Unsigned integer	UINT	2
UDINT	Unsigned double integer	UDINT	4
REAL	Floating point	FLOAT	4
TIME	Duration	UDINT	4
DATE	Date	UDINT	4
TIME_OF_DAY	Time of day	UDINT	4
DATE_AND_TIME	Date and time of day	UDINT	4
STRING	String	SHORT_STRING**	<i>n</i>
BYTE	Bit string length 8	USINT	1
WORD	Bit string length 16	UINT	2
DWORD	Bit string length 32	UDINT	4

** SHORT_STRING consists of a single-byte length field followed by the actual character data.

Arrays

Some parameters have multiple elements and are classified as parameter arrays. A parameter array has a parameter number that accesses the *whole* of the array. It also has parameter numbers that represent each *element* of the array.

Array Example: A parameter array called **VHZ_USER_FREQ** has 11 elements.

Parameter Number	Parameter - VHZ_USER_FREQ
0145	whole array
0146	index 0
0147	index 1
...	...
0157	index 10

If the parameter number of the whole array is 0145, then the parameter number of the element index 0 of the array will be 0134, the parameter number of the element index 01 will be 0147, etc.

String

A string parameter may be accessed via its parameter number. This is in the format of a SHORT_STRING. String arrays may not be accessed as a whole array but may be accessed via each element. Each element has its own parameter number.

APPENDIX B: Parameters

Function Block Inputs

Parameter Name	No.	Default Value	Range	Units	Type	Writable
COMMS REQUIRED	691	1: None	0: Unknown 1: None 2: CANopen 3: EtherCAT 4: Ethernet IP 5: Modbus RTU 6: Profibus 7: Profinet		ENUM	CONFIG
Communications option required.						
ADDR ASSIGNMENT	758	0: External	0: External 1: Fixed 2: DHCP		ENUM	CONFIG
Method for assigning the IP address.						
SET IP ADDRESS	759	0			ADDR	CONFIG
Ethernet option IP address						
SET SUBNET MASK	760	0			ADDR	CONFIG
Ethernet option subnet mask.						
SET GATEWAY ADDR	761	0			ADDR	CONFIG
Ethernet option gateway address.						
ACCESS	762	31: 31	0: IP Config Enable 1: Web Enable 2: Web Parameters Enable 3: FTP Enable 4: FTP Admin Mode		WORD	CONFIG
Ethernet access using comms option (bitwise)						
NODE ADDRESS	763	0			USINT	CONFIG
Communications node address.						
CANOPEN BAUD	764	9: Auto	0: 10 kbps 1: 20 kbps 2: 50 kbps 3: 100 kbps 4: 125 kbps 5: 250 kbps 6: 500 kbps 7: 800 kbps 8: 1000 kbps 9: Auto 10: Lss		ENUM	CONFIG
Required baud Rate for CANopen.						
MODBUS BAUD RATE	765	4: 19200 BPS	0: 1200 bps 1: 2400 bps 2: 4800 bps 3: 9600 bps 4: 19200 bps 5: 38400 bps 6: 57600 bps 7: 76800 bps 8: 115200 bps		ENUM	CONFIG
Required baud Rate for Modbus RTU						
PARITY	766	0: Even 1 Stop	0: Even 1 Stop 1: Odd 1 Stop 2: None 2 Stop 3: None 1 Stop		ENUM	CONFIG
Modbus parity and stop bits						
HIGH WORD FIRST	767	FALSE			BOOL	CONFIG
For 32-bit values high word comes first if set to TRUE.						
ACTIVE TIMEOUT	768	0	0 to 65		TIME	CONFIG
Process active timeout period.						

Parameter Name	No.	Default Value	Range	Units	Type	Writable
MASTERMAPPING	2566	TRUE			BOOL	CONFIG
Switch to choose how the PROFINet, EtherCAT, PROFibus and CanOpen PDO mapping is defined: If TRUE the bus master sets/configures the PDO mapping. The drive mapping parameters 692...757 are cleared (set to zero) and made invisible (GKP and website) as this the required condition. If FALSE the mapping parameters 692...757 are visible (Keypad and webserver) can be used to define the PDO mapping from drive side (which the bus master then can upload). The switch is considered during drive startup (stopped -> operational transition).						

Function Block Outputs

Parameter Name	No.	Default Value	Range	Units	Type	Writable
COMMS FITTED	769	0: Unknown	0: Unknown 1: None 2: CANopen 3: EtherCAT 4: Ethernet IP 5: Modbus RTU 6: Profibus 7: Profinet		ENUM	NOT
Communications option fitted.						
COMMS VERSION[0]	770	0			USINT	NOT
Firmware version of the comms module.						
COMMS VERSION[1]	770	0			USINT	NOT
Firmware version of the comms module.						
COMMS SERIAL NUM	773	0			DWORD	NOT
Serial number of the comms module.						
COMMS STATE	774	8: None	0: Setup 1: NW Init 2: Wait Process 3: Idle 4: Process Active 5: Error 6: Reserved 7: Exception 8: None		ENUM	NOT
State of the option comms.						
DIAGNOSTIC	775	0: Ok	0: Ok 1: Hardware Mismatch 2: Invalid Configuration 3: Mapping Failed 4: Exception 5: Unsupported Option 6: Not Responding		ENUM	NOT
Diagnostic for the comms option.						
EXCEPTION CODE	776	0			WORD	NOT
Diagnostic code on option entering exception state. The MSB is the exception code and the LSB is the exception info.						
COMMS SUPERVISED	777	FALSE			BOOL	NOT
Indicates a master has made a connection to the device.						
MAPPING CHANGED	778	FALSE			BOOL	NOT
The PLC has changed the process data mapping from that set by the drive.						
STATION NAME	779				STRING	NOT
Current PROFINET station name.						
IP ADDRESS	787	0			ADDR	NOT
Current Ethernet option IP address.						
SUBNET MASK	788	0			ADDR	NOT
Current Ethernet option subnet mask.						
GATEWAY ADDRESS	789	0			ADDR	NOT
Current Ethernet option gateway address.						

Parameter Name	No.	Default Value	Range	Units	Type	Writable
ACTUAL BAUD RATE	790	0: 10 kbps	0: 10 kbps 1: 20 kbps 2: 50 kbps 3: 100 kbps 4: 125 kbps 5: 250 kbps 6: 500 kbps 7: 800 kbps 8: 1000 kbps 9: Auto 10: lss		ENUM	NOT
Actual CANopen baud rate.						

APPENDIX C: Setting IP-Address via Anybus IPCONFIG

Use the IPCONFIG tool from HMS to search and set slave IP Addresses. The Anybus IPCONFIG utility can be downloaded free of charge from the HMS website. This utility may be used to configure the network settings of any Anybus product connected to the network.

On starting the program, the network is scanned for Anybus products. The network can be rescanned at any time by clicking 'Scan'.

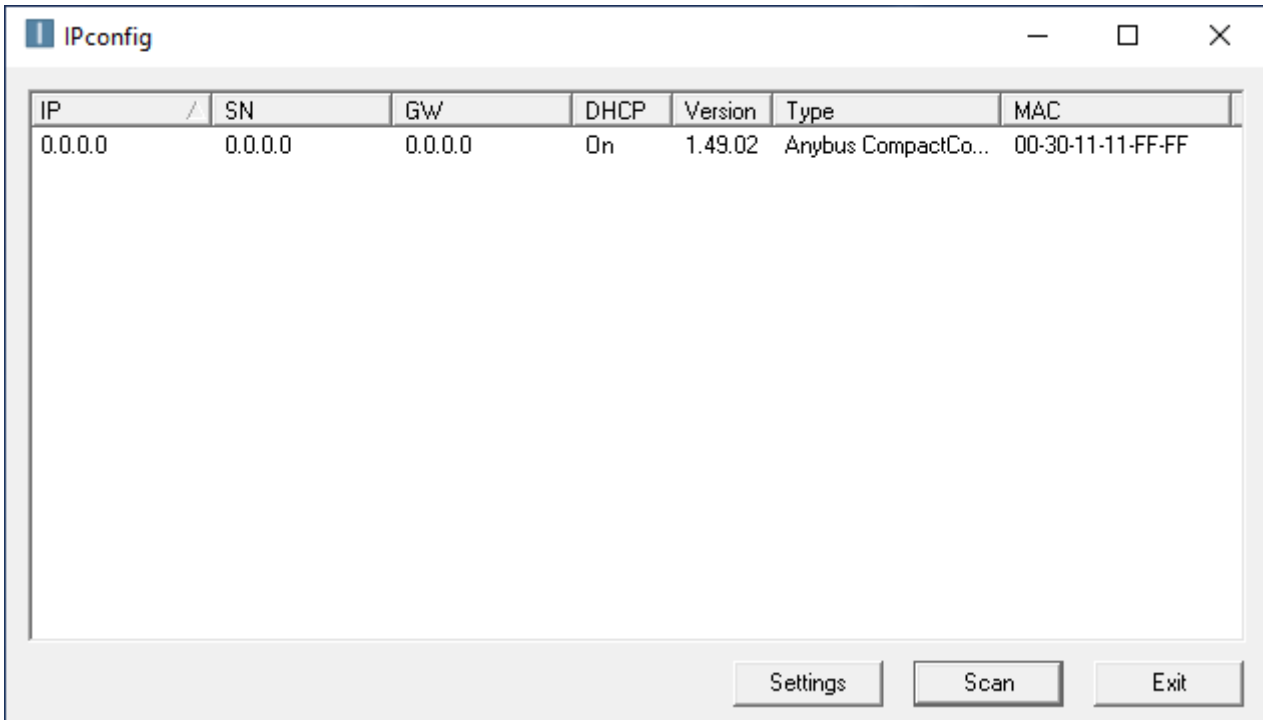

In the list of detected devices, double-click on the entry in the list. A window will appear, containing the IP configuration and password settings. Validate the new settings by clicking 'Set', or click 'Cancel' to abort

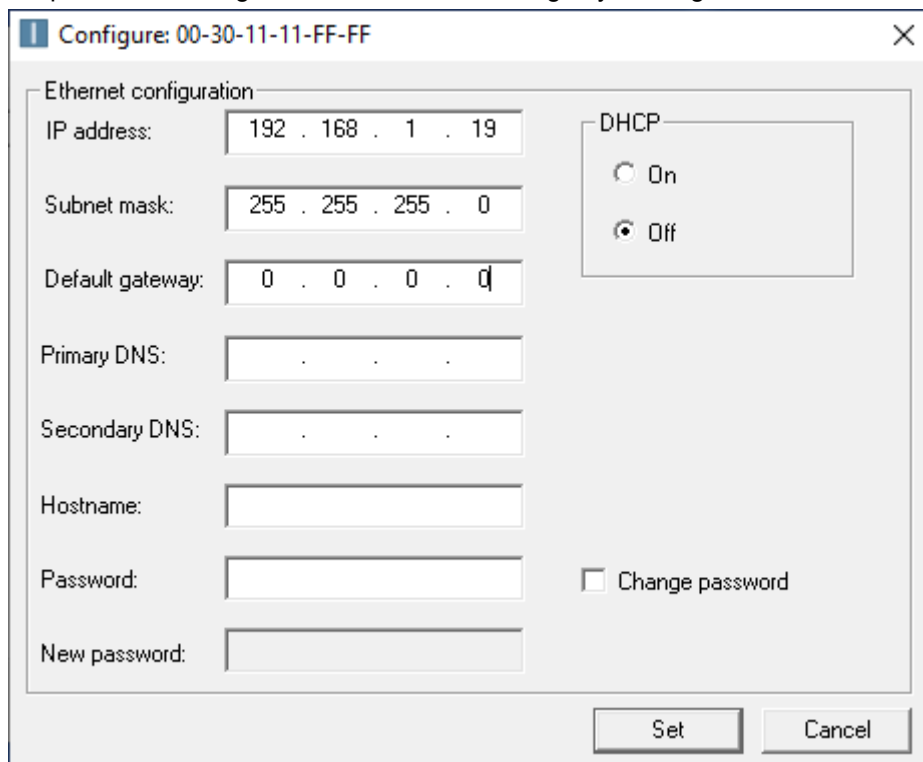

APPENDIX D: DSE Lite Quick Start Guide

Follow the steps below to configure the AC20 via DSE Lite PC-Tool.

The block diagram of the AC20 may be accessed through the onboard webserver or DSE Lite.

DSE Lite is recommended.

The IP address of the AC20 is in the range 169.254.xx.xx by default. Therefore, the user's PC network adapter must be configured to this range as shown below (IPv4 is used for communication).

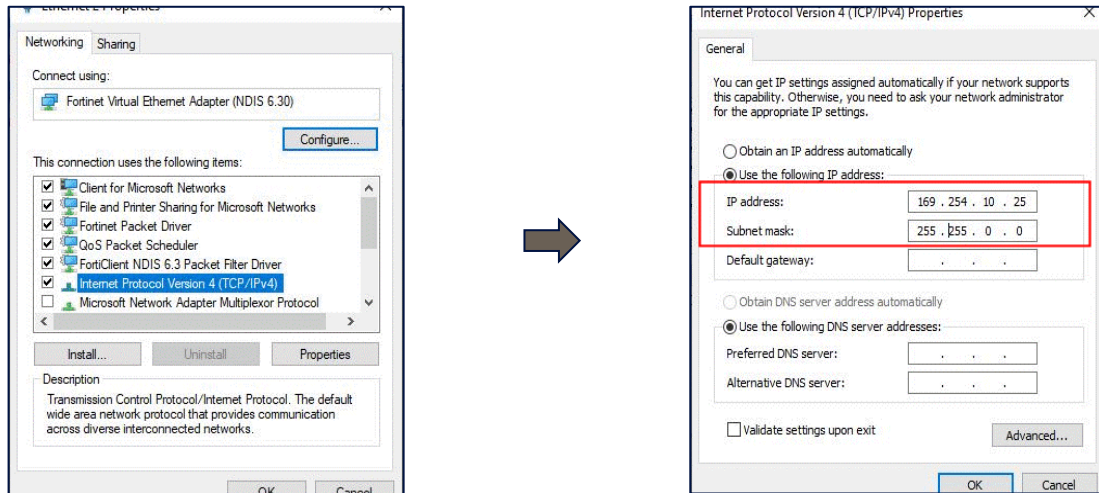

Alternatively, the IP address of the drive may be changed to suit the settings of the PC network adapter. The IP address of the drive can be configured using the DCT function, accessible from within DSE Lite by selecting Command -> Install AC15/AC20 Firmware.

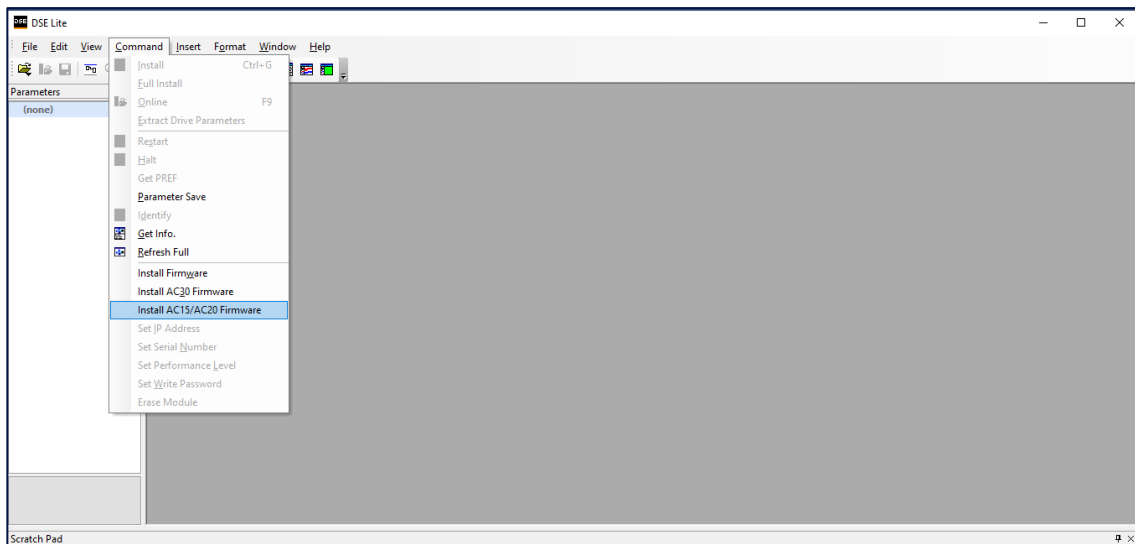

Once the network scan is completed, then the drive settings can be edited.

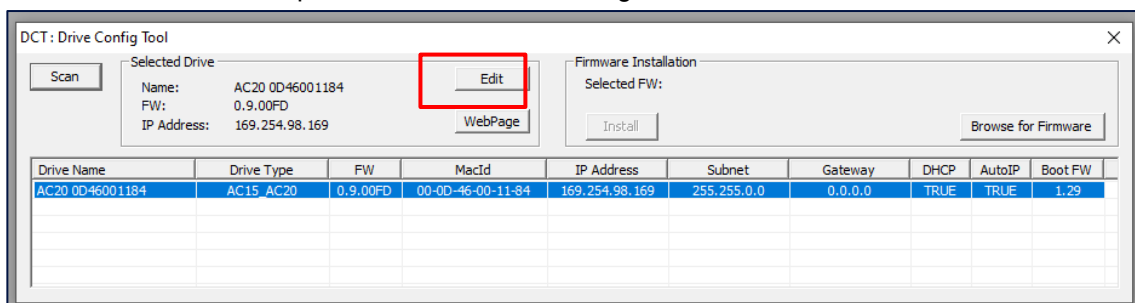

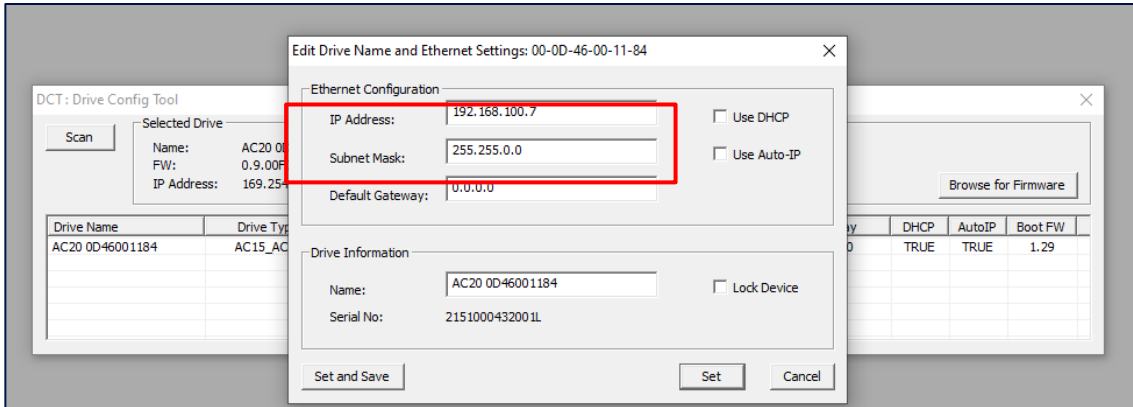

If the drive is not found by DSE lite, or a new drive is connected to the Ethernet port, a network scan must be performed again, as blow.

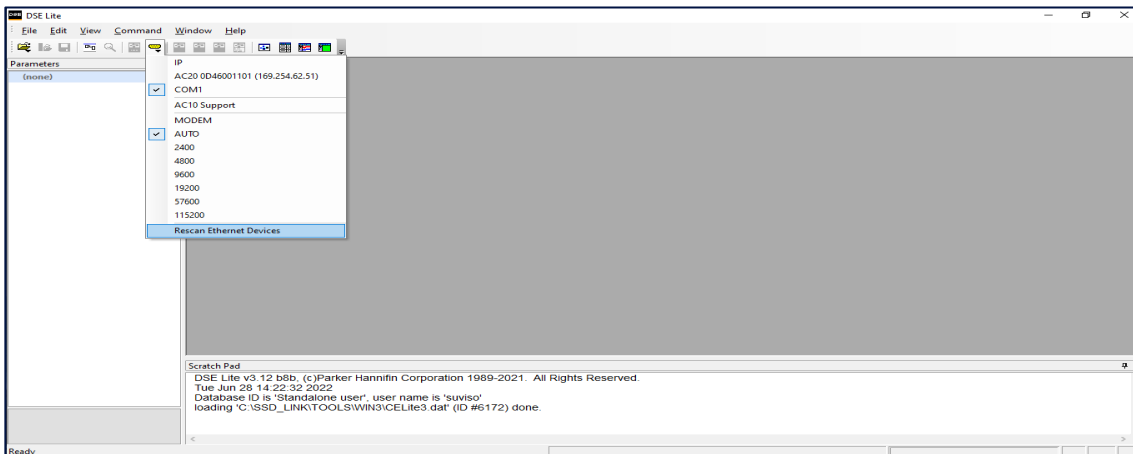

Once the network scan has been performed, any AC20 connected to the network will appear and DSE lite can connect to the drive.

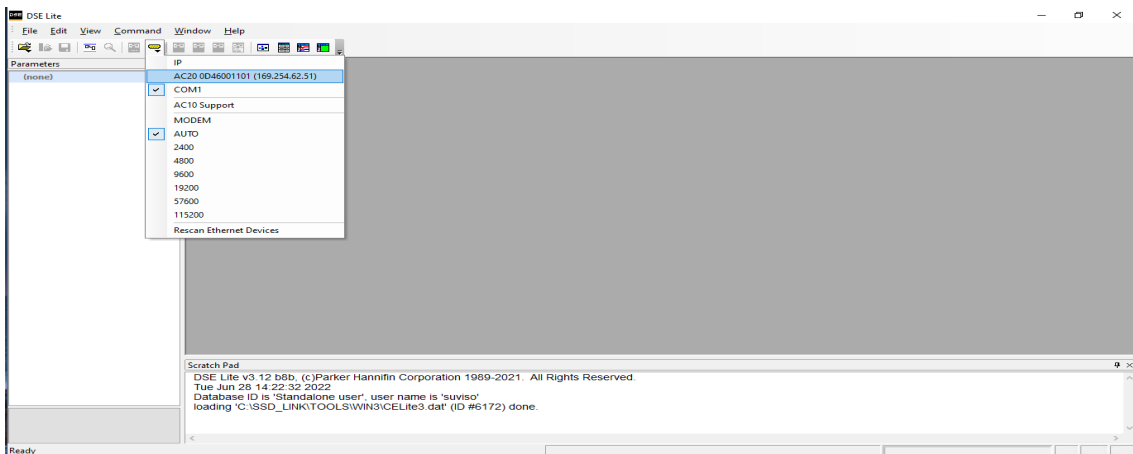

When connected to a drive, this is shown in the scratch pad.

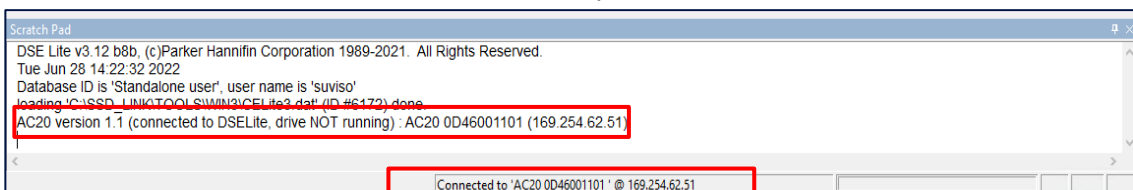



EMAC s.r.o.
Kasarenska 2404/26
911 05 Trencin
SLOVAKIA

Parker certified distributor

 +421 32 3810 232

 info@emac.sk

 www.emac.sk